

EV300 Series

Three Phase Intelligent Power Meter



Power System Metering
Analog Transducer Output
True-RMS Measuring

Remote Switch Controlling
Local/Remote Data Accessing
Hidden Key Design



ISO9001 Certified



DESCRIPTION

EV300 Series Three-Phase Intelligent Power Meters are an excellent choice when continuous monitoring and measuring are required. This compact meter provides measurement of a wide range of Electric Parameters and Functionality such as:

- Voltage
- Current
- Power
- Reactive Power
- Apparent Power
- Power Factor
- Frequency
- Energy

The 2 Relay outputs are for Electric Switch controlling while Switch status monitoring is possible by using the 6 switch (DI) inputs. Two Analog Outputs can be used in DCS systems or industrial apparatus. The EV300 series combines high accuracy measurement with intelligent multifunction capabilities with a simple HMI interface.

The EV300 may be used as a data acquiring device for an Intelligent Power Distribution Automation System or a Plant Automation System that integrates process, instrument and electrical requirements. All monitored values are available via RS485 communication ports running the Modbus™ protocol. The EV300 series meter is suitable for AC applications where there is considerable distortion of current waveforms from nonlinear loads such as a VVVF Inverter, Ballastor and Switching Power Supply.

APPLICATIONS

- Metering of distribution feeders
- Medium and low voltage systems
- Commercial, industrial, utility
- Industrial apparatus

EV300 Series Three-Phase Intelligent Power Meters

Function				EV361	EV362	EV382	EV384	EV387	EV390
METERING	Voltage	V	V	•		•		•	•
	Current	I	A		•	•		•	•
	Power	P	kW				•		•
	Reactive Power	Q	kvar				•		•
	Apparent Power	S	kVA						•
	Power Factor	PF					•		•
	Frequency	F	Hz						•
ENERGY	Energy	Ep	kWh					•	•
	Reactive Energy	Eq	kvarh					•	•
DI OPTION	Digital Input	2DI		•	•	•	•	•	•
		4DI		⊙	⊙	⊙	⊙	⊙	⊙
RO/DO OPTION (either-or)	Relay Output	2RO		⊙	⊙	⊙	⊙	⊙	⊙
	Digital Output	2DO						⊙	⊙
AO/PO OPTION (either-or)	Analog Output	4~20mA		⊙	⊙	⊙	⊙	⊙	⊙
		0~1mA							
	Auxiliary Power	24Vdc		⊙	⊙	⊙	⊙	⊙	⊙
COMMUNICATION (either-or)	RS485, Modbus-RTU protocol			•	•	•	•	•	•
	RS485, DL/T645 protocol							⊙	⊙
DISPLAY	LCD Display			•	•	•	•	•	•
SIZE				96x96x73mm					

• Function ⊙ Option Blank NA

Analog Output

2 Analog Output optionally

Digital Input

6 Digital Inputs for Electric Switch controlling

Metering

Voltage	V1 V2 V3 Vavg	V12 V13 V23 Vavg
Current	I1 I2 I3 Iavg	
Power	P	
Reactive Power	Q	
Apparent Power	S	
Frequency	Hz	
Power Factor	PF	
Energy	Ep	Eq
Reactive Energy	Eq	

Display

Large characters displayed on a clear, blue backlight LCD display. The display is highly tolerant to a wide range of temperatures.

TYPICAL WIRING

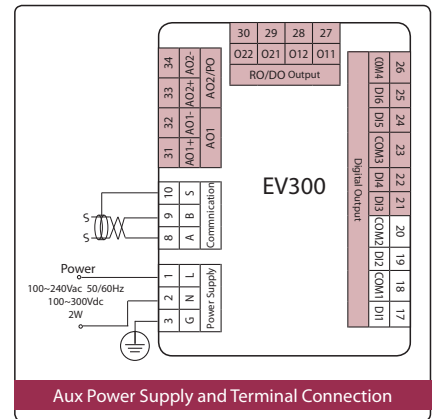
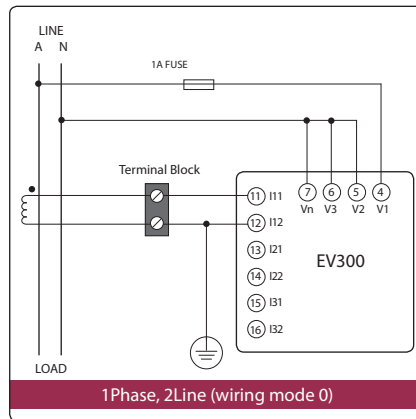
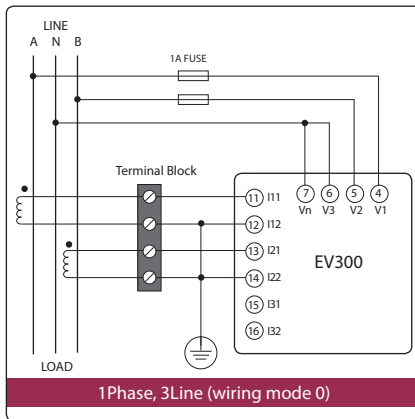
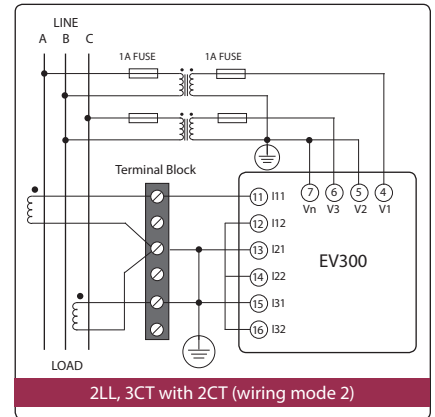
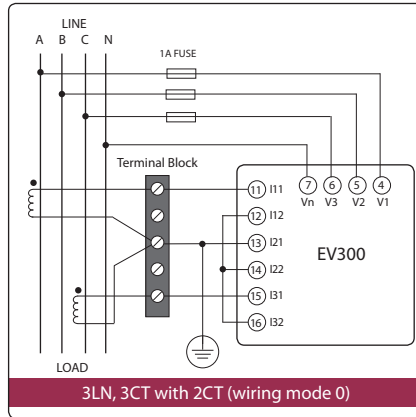
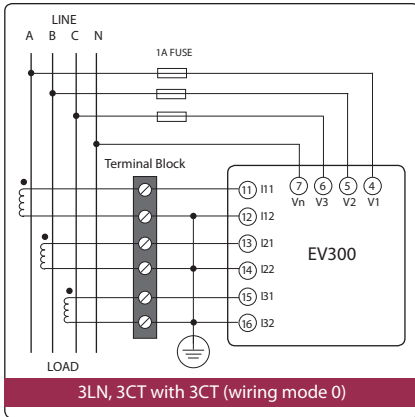

METERING

Parameter	Accuracy (% of Full Scale)	Resolution	Range
Voltage	0.5%	0.1%	20V~500kW
Current	0.5%	0.01%	0~9999A
Power	1.0%	0.1%	-9999~9999MW
Reactive Power	2.0%	0.1%	-9999~9999MVar
Apparent Power	1.0%	0.1%	0~9999MVA
Power Factor	1.0%	0.1%	-1.000~0~1.000
Frequency	0.2%	0.01Hz	45.00~65.00Hz
Energy	0.5%	0.1kWh	0~99999999.9kWh
Reactive Energy	2.0%	0.1kvarh	0~99999999.9kvarh
others	0.5%		
Temperatuer coefficient	<100 ppm/°C (0~50°C)		

DIMENSIONS

Unit: mm (inches)

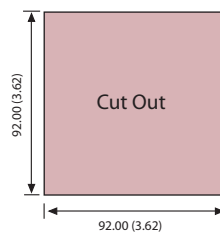
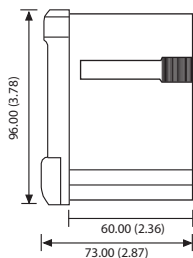
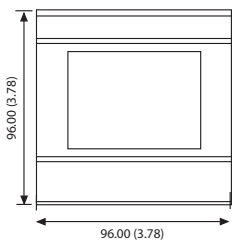

TECHNICAL SPECIFICATIONS

INPUT	
AC CURRENT	
CT Input	5A Secondary (1A Secondary Option)
Burden	0.2VA
Overload	2×CT for Continue 20×CT for 1 Second
Full Scale	120% of CT
Accuracy	0.5% of Full Scale, True RMS
AC VOLTAGE	
PT Pri/Sec	Direct or 100~500,000:100~400
Input Range	20~400V
Burden	<0.2VA
Accuracy	0.5%
SWITCH STATUS (DI)	
Optical Isolated Voltage	2500Vac RMS
Input Type	Wet Contact
Resistance	2K ohm (Typical)
Input Voltage	5~30Vdc
Max Input Current	20mA

COMMUNICATION	
Type	RS485 2 wire, half duplex, isolated
Baud Rate	600 to 38400 bps
Protocol	Modbus®RTU
Function	Read/Write setpoints Read actual values Execute commands

OUTPUT	
RELAY OUTPUT (RO)	
Type	Mechanical Contact
Contact Resistance	30m ohm@1A
Max Break Voltage	250Vac, 100Vdc
Max Break Current	3A
Configuration	Form A
Output Mode	Latch or Momentary (50-3000ms Configurable)
ANALOG OUTPUT (AO)	
Output Range	4~20mA or 0~1mA or 0~5V
Resolution	12bit
Output Capability	4~20mA Max Load: 750Ω 0~1 mA Max Load: 10K Ω 0~5 V Max Current: 20mA
SWITCH STATUS (DI)	
Optical Isolated Voltage	2500Vac RMS
Input Type	Wet Contact
Resistance	4K ohm (Typical)
Input Voltage	5~30Vdc
Max Input Current	7.5mA

ENVIRONMENTAL	
Humidity	5% to 95% non-condensing
Temperature	-25°C to 70°C
Shipping Weight	0.5Kg

ORDERING INFORMATION

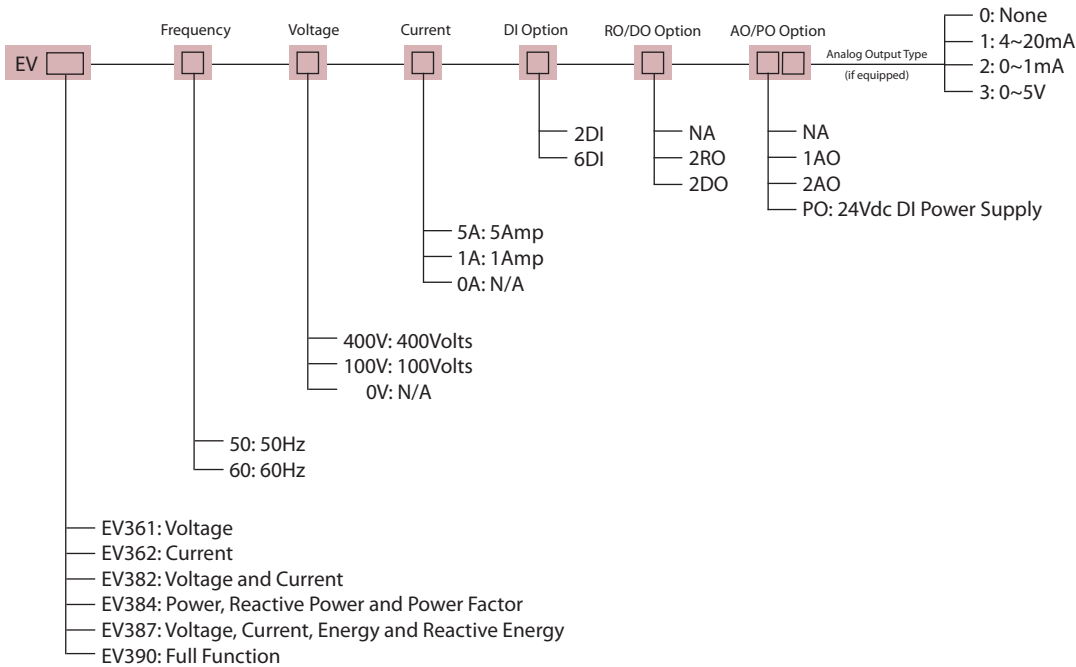

EV Series Meter Ordering Example: EV390 - 60 - 400V - 5A - 6DI - 2RO - 2AO1



Accuenergy Corporation
Los Angeles-Toronto-Beijing
North America Toll Free: 1-877-721-8908
Web: www.accuenergy.com.cn
Email: marketing@accuenergy.com

Revision Date: Aug., 2010
Document # 1003E1120