

AcuCT A Series

AcuCT-200A

Revenue Grade Split-Core
Current Transformer Datasheet

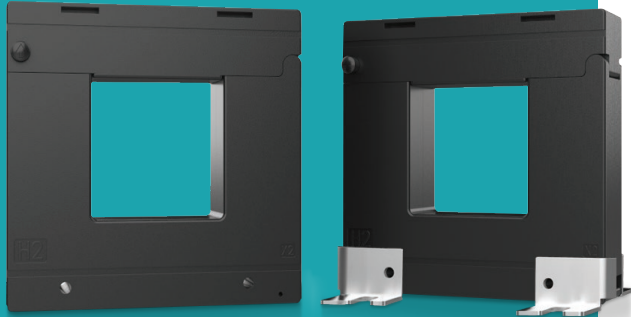

The AcuCT-200A is a premium, revenue grade split-core current transformer designed for high accuracy energy measurements and power monitoring applications. Multiple output options and class 0.5S accuracy, depending on the model, makes it ideal for metering and billing verification. The user-friendly press-open design with a durable, compact form factor enables fast installation. Optional zinc-plated mounting accessory provides stable connection and corrosion resistance for safety and quality in challenging applications.

Features

- Revenue grade accuracy compliant with IEC 61869-2 Class 0.2, Class 0.5, and Class 0.5S from 1% - 120% of rated current.
- Multiple output options including 80mA, 100mA, and 333mV.
- Wide frequency for reliable operation from 50Hz to 400Hz.
- Press-open split-core design enables quick and simple installation.



Specifications

RATED CURRENT	400A, 500A, 600A, 750A, 800A, 1000A, 1200A, 1500A
Current Range	1% - 120%; 5% - 120% of Rated Current
Output	80mA, 100mA, 333mV
Accuracy	IEC 61869-2 Class 0.5 @ 400A - 500A IEC 61869-2 Class 0.5S @ 600A - 1500A @ 80mA and 100mA IEC 61869-2 Class 0.2 @ 600A - 1500A @ 333mV

MECHANICAL/ENVIRONMENTAL

Form Factor	Press Open Split-Core CT
Window Size	51 mm x 51 mm (2.01" x 2.01")
Exterior Dimensions	111 mm x 115 mm x 32 mm (4.37" x 4.53" x 1.26")
Case Material	UL 94V-0 Rated Flame Retardant
Lead Wires	2.5 m (8 ft), Twisted Pair, 16 / 18 AWG
Operating Temperature	-25°C to 70°C / -13°F to 158°F
Storage Temperature	-40°C to 80°C / -40°F to 176°F
Operating Humidity	Non-Condensing, 5% to 95% RH
Installation Conditions	Indoor Use

ELECTRICAL

Wire Polarity	White=Positive, Black=Negative
Phase Orientation	H1 Points Towards Source
Frequency Range	50 Hz - 400 Hz
Burden @ 80mA and 100mA Output	2.5 Ω - 10 Ω @ mA Output
Insulation Resistance	500V / 100 MΩ min

SAFETY/COMPLIANCE

Withstand Voltage	5.0 kV / 1 mA / 1 min
Rated Voltage	600VAC, Rated CAT IV, PD3
Certifications & Compliance	CE, RoHS, UL Listed UL2808, CSA 22.2, IEC 61010-1, and IEC 61869-2

Dimensions

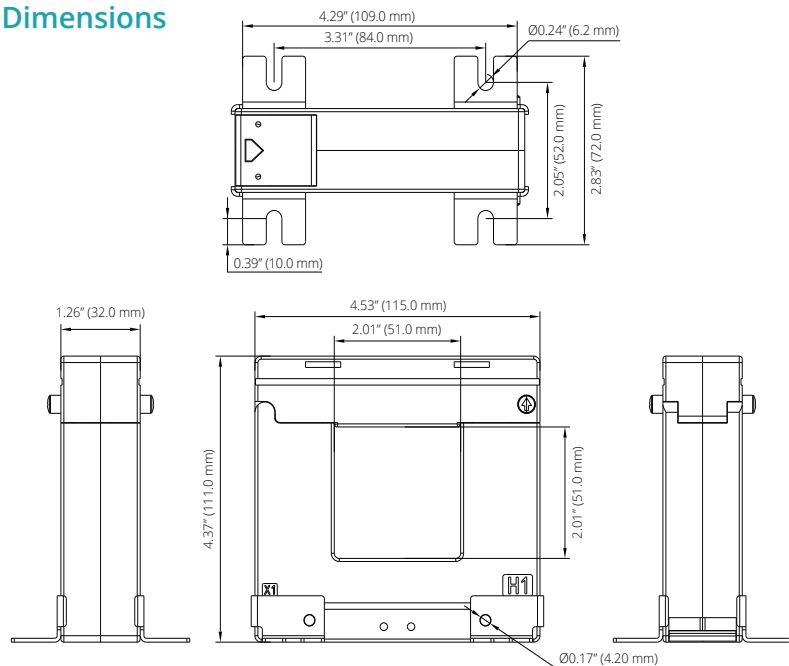

Mounting Accessory

Optional mounting kit is available which can be used to secure the device. Each kit includes 4 mounting brackets, 2 mounting screws (M4 x 40 mm), and 2 mounting nuts (M4 x 3 mm or M4 x 5 mm). The zinc-plated accessory provides corrosion protection and is recommended to be tightened at torque of 0.5 to 0.8 N·m.

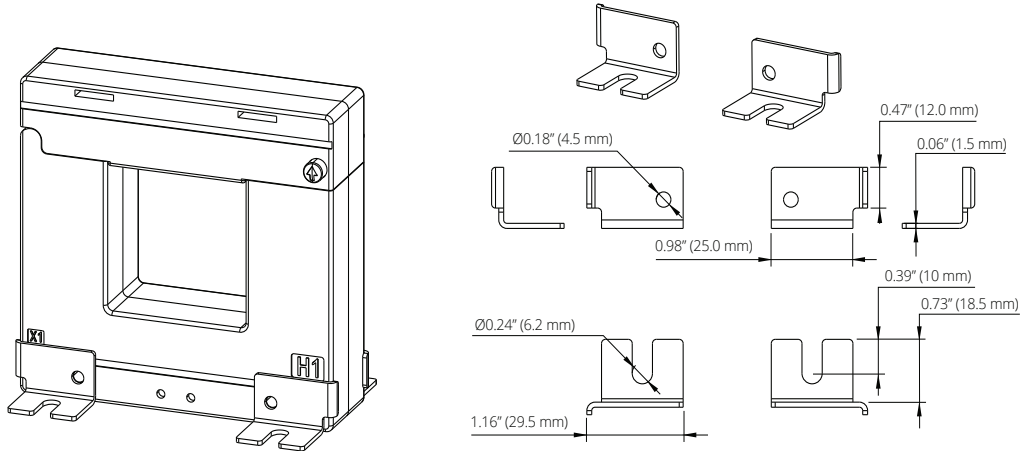

Installation Instructions

1. Press the buttons on both sides of the upper housing of CT to open it, so that the primary conductor cable is connected to the current transformer.

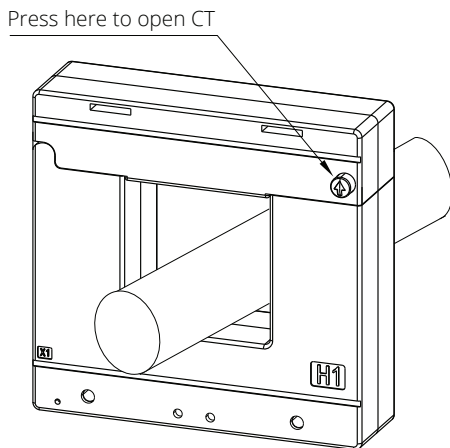

2. Insert the primary conductor cable through the window from H1 side, which must point towards the source. The white wire is the positive lead, and the black wire is the negative lead. This will ensure correct phase orientation during installation.

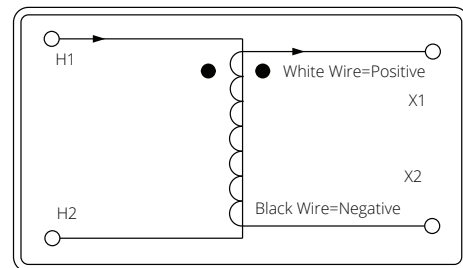

Ordering Information

Model	-	Rated Input	:	Rated Output
AcuCT-200A		400: 400A		80mA
		500: 500A		100mA
		600: 600A		333mV
		750: 750A		
		800: 800A		
		1000: 1000A		
		1200: 1200A		
		1500: 1500A		

Ordering Example AcuCT-200A - 400 : 100mA

+ Accessory (Optional)

Model	Accessory
ACUBRAC	SP7
Ordering Example	ACUBRAC - SP7



Accuenergy Inc.

Los Angeles - Toronto - Pretoria
 North America Toll Free: 1-877-721-8908
 Web: www.accuenergy.com
 Email: marketing@accuenergy.com

Revision Date: May 2026 Version: 1.0.0
 Specs Subject To Change Without Notice.