



# AcuRev 1310 DIN-Rail Power Meter Users Manual

**Copyright © 2024 Version: 1.2.5**

This manual may not be altered or reproduced in whole or in part by any means without the expressed written consent of Accuenergy.

The information contained in this document is believed to be accurate at the time of publication, however, Accuenergy assumes no responsibility for any errors which may appear here and reserves the right to make changes without notice. Please ask the local representative for latest product specifications before ordering.

Please read this manual carefully before installation, operation and maintenance of the AcuRev 1310 series meter. The following symbols in this manual are used to provide warning of danger or risk during the installation and operation of the meters.



**Electric Shock Symbol: Carries information about procedures which must be followed to reduce the risk of electric shock and danger to personal health.**



**Safety Alert Symbol: Carries information about circumstances which if not considered may result in injury or death.**

Prior to maintenance and repair, the equipment must be de-energized and grounded. All maintenance work must be performed by qualified, competent accredited professionals who have received formal training and have experience with high voltage and current devices. Accuenergy shall not be responsible or liable for any damages or injuries caused by improper meter installation and/or operation.

# Table of Contents

<b>Chapter 1: Introduction .....</b>	<b>5</b>
1.1 Meter Overview .....	6
1.2 Areas of Application .....	7
1.3 Product Features.....	7
<b>Chapter 2: Installation .....</b>	<b>9</b>
2.1 Appearance and Dimensions.....	11
2.2 Installation Methods .....	12
2.3 Wiring.....	13
2.3.1 Terminals:.....	15
2.3.2 Auxiliary Power Supply: .....	15
2.3.3 Voltage Input: .....	16
2.3.4 Current Input:.....	17
2.3.5 Relay Output Wiring Diagram .....	24
2.3.6 Communication .....	25
<b>Chapter 3: Operation and Application .....</b>	<b>26</b>
3.1 Display Panel and Keys.....	27
3.2 Display Mode and Key Operations.....	28
3.2.1 Important parameter display mode:.....	28
3.2.2 All parameter display mode: .....	28
3.2 Parameter Display and Key Operations .....	29
3.4 Settings and Operations:.....	32
3.4.1 Settings Mode.....	32
3.5 Meter Configuration .....	35
3.5.1 Initial Setup .....	35
<b>Chapter 4 Functions Functions and Software .....</b>	<b>39</b>
4.1 Introduction to AcuRev 1310 Utility Software .....	40
4.2 Parameter Settings.....	42
4.2.1 Wiring Method & CT/PT Settings .....	42
4.2.2 Reactive Power Calculation:.....	43
4.2.3 Modbus Communication Options: .....	43
4.2.4 Energy Pulse Output .....	44
4.2.5 Demand .....	45

4.2.6 Sealing Option.....	46
4.2.7 Communication Permission.....	47
4.2.8 Display Parameters.....	48
4.2.9 Energy Decimal Places & RO output mode:.....	49
4.3 Real-time Metering.....	49
4.4 Measurement Function.....	51
<b>Figure 4-20 Weekend Setting in TOU configurations page.....</b>	<b>53</b>
4.4.1 TOU Seasons.....	53
4.4.2 Daylight Saving Time (DST).....	55
4.5 Event Logging.....	56
4.6 Alarm Function.....	58
4.6.1 Configuring the Alarm.....	60
4.6.2 Reading the Alarm.....	60
4.7 Incorrect Connection Detection.....	61
4.8 Sealing Function.....	62
4.9 Device Information.....	65
<b>Chapter 5: Communication.....</b>	<b>66</b>
5.1 Modbus Protocol Information.....	67
5.1.1. Transmission Mode.....	67
5.1.2. Frame.....	67
5.2 Communication Format.....	68
5.3 Application Details.....	70
5.3.1 Data Types.....	70
5.3.2 Relationship between Communication value and Real value.....	70
5.3.3 Parameter Address Table.....	71
5.4 BACnet Protocol Information.....	104
5.4.1 BACnet Overview and Introduction.....	104
5.4.2 BACnet Protocol on the AcuRev 1310 Series Power.....	105
5.4.3 Initializing BACnet Protocol on the AcuRev 1310 Meter.....	106
5.4.4 BACnet Objects.....	109

**Appendix ..... 113**  
Appendix A – Functions List ..... 113  
Appendix B Technical Specifications and Parameters ..... 114  
Appendix C Revision History ..... 115  
Appendix D Alarm Parameters Comparison Table ..... 115  
Appendix E Meter Event Flags: bit32 ..... 116



# Welcome to the AcuRev 1310!

You have purchased an advanced, versatile, multifunction power meter.

Please note the following chapter descriptions in order to utilize the power meter properly.

**Chapter 1** introduces the basic AcuRev 1310 features and application areas.

**Chapter 2** introduces the AcuRev 1310 installation and wiring methods in detail.

**Chapter 3** walks through how to operate the AcuRev 1310 via the display panel, display measurement data and parameter settings.

**Chapter 4** introduces main functions with the included software.

**Chapter 5** introduces communication related information, including communication protocol format and parameter address table.

**Appendix** provides AcuRev 1310 technical specifications and ordering information.



# *AcuRev 1310* DIN-Rail Power Meter

## Chapter 1: Introduction

---

1.1 Meter Overview

1.2 Areas of Application

1.3 Product Features



## 1.1 Meter Overview

The AcuRev 1310 series is a DIN rail-mounted, three phase energy meter that is small in size with high accuracy. The meter is equipped with an easy to read liquid crystal display (LCD) which conveys all the important data. It is ideal for building energy management systems, energy monitoring and energy metering systems.

### Energy

The AcuRev 1310 series supports bi-directional active energy measurements, as well as two-way reactive power energy metering, and four quadrant reactive power energy metering. It also supports apparent energy metering, the cumulative energy metering (Energy Import + Energy Export), and net energy metering (input power - output power).

### Measurement Function

The AcuRev 1310 series meters provides real-time RMS measurement of the instantaneous Voltage, Current, Power, Frequency and Power Factor. All measurements can be viewed through the meter display as well as the AcuRev 1310 Utility Software.

### Demand

This product provides demand measurement of Current, Active Power, Reactive Power and Apparent Power. It also provides demand forecasting as well as the peak demand.

### System Event Logging

The AcuRev 1310 series meter can record the time and event regarding important parameter events.

- **Run time of meter**  
Supports meter running time of measurements and events.
- **Alarm function**  
Supports multiple parameter alarms, and can be configured to trigger Relay Output.

### Communication

This meter supports Modbus RTU and BACnet MS/TP communication protocols, both over serial RS485. The meter also has an infrared interface.

### 1.2 Areas of Application

Large Commercial Center  
School  
Hotels and Buildings  
Smart Building System  
Industrial Environment

Rail Transport  
Public Facilities  
Smart Distribution Cabinet  
Energy Management System  
Energy Saving System

### 1.3 Product Features

#### Multifunction, high accuracy

AcuRev 1310 series meter has data collection and management for energy and multi-parameters measurement. It also features demand measurement and event logging.

The measurement accuracy of energy, power, voltage, and current is 0.5%.

#### Small size, convenient installation

The appearance and dimension of the AcuRev 1310 series meter is designed in accordance with the IEC 35mm DIN standard.

#### Clear Display

The AcuRev 1310 series features a clear display to provide visibility in all environments. All measurement parameters can be found and easily accessed through the display. The LCD display has backlight support that can aid users in weak lighting environments.

#### Safety

AcuRev 1310 series product has both an electronic and physical sealing function. It is designed in such a way that it cannot be opened without leaving signs of tampering. Users cannot change the parameters through the display when the electronic sealing is closed, and important parameters cannot be changed through communication, thus preventing data or configurations from being altered.

## Convenient wiring

It supports both high voltage systems and low voltage systems, as well as both three-phase three-wire systems and three-phase four-wire systems. Users can choose the appropriate wiring configuration for the AcuRev 1310 series meter. The AcuRev 1310 series meter can be used for single phase systems as well.

## Wiring Check

The AcuRev 1310 series meter has a connection error feature that helps to reduce wiring errors.

## Chapter 2: Installation

---

### 2.1 Appearance and Dimensions

### 2.2 Installation Methods

### 2.3 Wiring



## Before Installation

The installation must be performed by qualified, competent accredited professionals who has received formal training and has experience with high voltage and current devices. Appropriate safety wear (gloves, glasses, arc flash suit, etc.) is mandatory to ensure safe installation.

During normal meter operation, caution should be used when handling the following as high voltage may be present:

- Terminal Blocks
  - Current/Potential Transformer leads and the related circuits
  - All primary and secondary circuits may contain lethal current and voltage.
  - Contact with current channels must be avoided.
- 
- ✓ The power meter and I/O modules cannot be installed on the primary side of transformers or where VA has limitations. The power meter can be only installed on the secondary side. Avoid contact with meter terminals after the completion of installation.
  - ✓ Do not supply input voltage above the rated maximum limit of the power meter and devices connected to it. Before energizing the meter, please refer to the meters label and specifications.
  - ✓ Do not perform high voltage test or insulation experiments to output, input or communication terminals.
  - ✓ The use of shorting blocks and fuses are recommended. Current transformers need to be grounded (5A/1A).
  - ✓ Use dry cloth to wipe the meter.

This chapter mainly describes the installation process of the AcuRev 1310 series meter, which is a very important step in using the meter correctly. This chapter provides information and diagrams about how to install the meter. Before installing the meter, please read through this section first.

## 2.1 Appearance and Dimensions



Figure 2-1 AcuRev 1310 Front Display

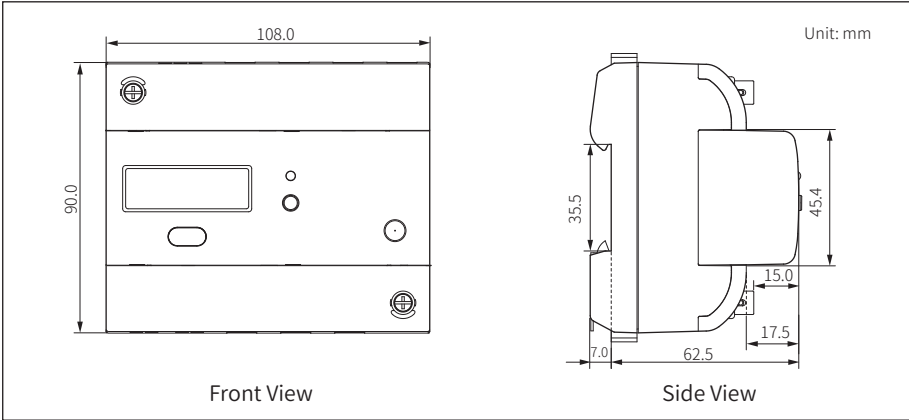

Figure 2-2 AcuRev 1310 meter Front and Side Dimensions

## 2.2 Installation Methods

### Environmental

Before installation, please check the environment, temperature, and humidity to ensure the AcuRev 1310 series meter is being placed in an environment that are within temperature and humidity specifications.

### Temperature

AcuRev 1310 operating temperature is -25 ~ 75° C. Exceeding this temperature range will cause damage to the meter and will affect the accuracy and functionality. Please note this can influence the meters life negatively if the meter operates in extremely high or extremely low temperatures. AcuRev 1310 storage temperature range is 40~85° C.

### Humidity

5% to 95% non-condensing.

### Location

AcuRev 1310 series meter should be installed in a dry and dust free environment. Avoid exposing the meter to excessive heat, radiation and high electrical noise sources.

### Installation Steps:

This product is DIN railed mounted and fits on a standard 35mm rail.

1. To install the meter on the rail insert the top of the rail into the groove on the back of the meter. Pull the metal clips back and slide the rail across the groove of the meter.

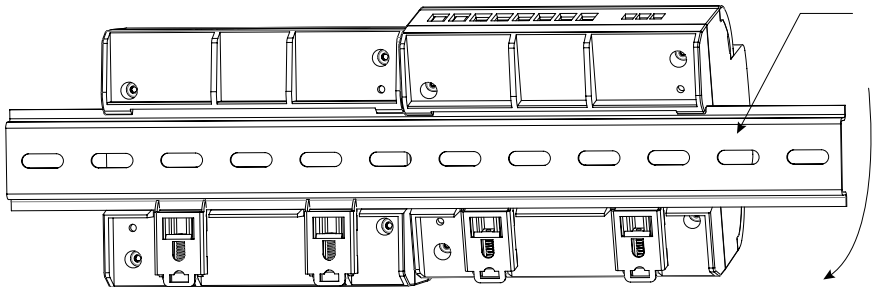



Figure 2-3 Step A

 **Note**  
Temperature and humidity of the environment must accord with the requirement of AcuRev 1310, Otherwise it may cause the meter damaged.



2. Use the metal clips to tighten onto the rail to complete installation.

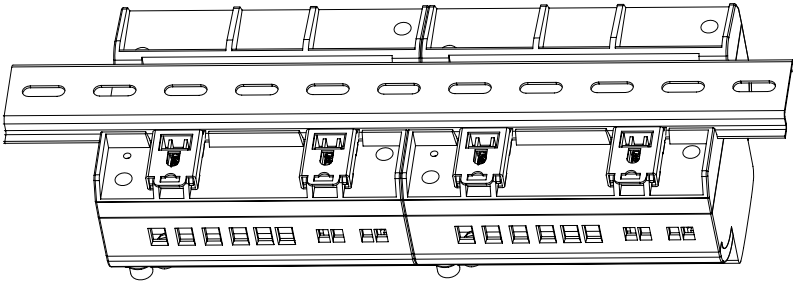

Figure 2-4 Step B

## 2.3 Wiring

The terminals of the AcuRev 1310 series can be accessed by first removing the terminal covers on the meter.

1. To open the terminal cover, remove the seal if applicable, and then unscrew the sealing screws and lift the cover upwards to remove.

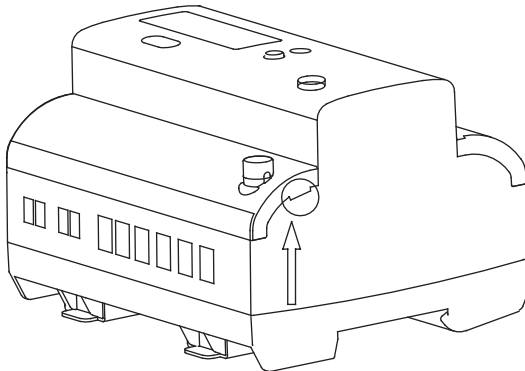

Figure 2-5 Removing terminal cover

2. To attach the bottom terminal cover back onto the meter, place the left side of the cover down into the groove first and then press down onto the right side, see Figure 2-6. When installed correctly, you will hear a clicking sound. To attach the top cover place the right side of the cover down into the groove and press down onto the left side.

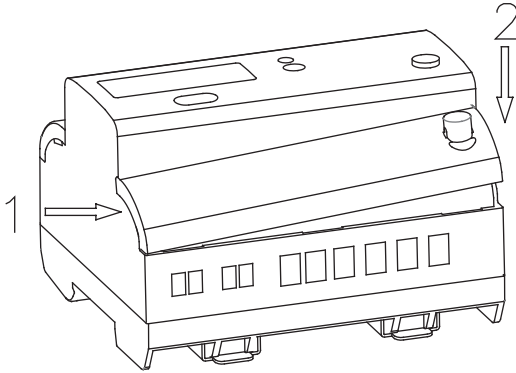

Figure 2-6 Attaching terminal cover onto meter

3. 3. After inserting the cover, tighten the sealing screws and place the seal.

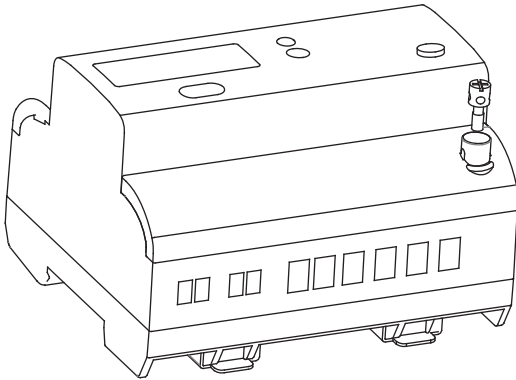

Figure 2-7

### 2.3.1 Terminals:

This manual uses V1, V2, V3 to represent three-phase conductors, which would be the same as Va, Vb, Vc in other manuals.

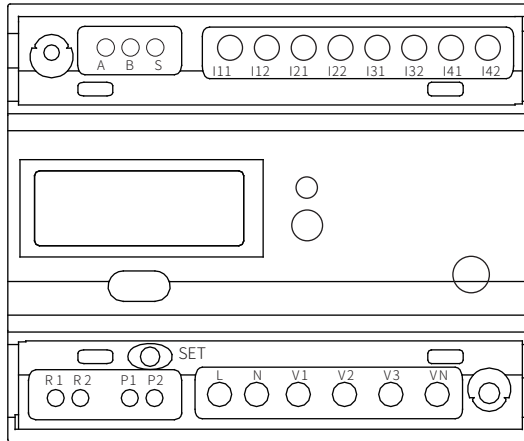

Figure 2-8 AcuRev 1310 Series Terminals

- Communications Terminal: A, B, S
- Pulse Output: P1, P2
- Auxiliary Power: L, N
- Voltage Inputs: V1, V2, V3, VN
- Current Inputs: I11, I12, I21, I22, I31, I32, I41, I42
- Relay Output: R1, R2

### 2.3.2 Auxiliary Power Supply:

The AcuRev 1310 series meter requires a power supply of 100 ~ 415 Vac at 50/60 Hz. For use of other power supply voltage selections please contact the manufacturer. The meter typically has small power consumption (less than 1W) so the power supply can be an independent power supply, or can also be obtained from the circuit under test.

It is suggested that under the condition that the power voltage fluctuation is large, to use a voltage stabilizer. The power supply terminals respectively are: L, N.

The typical auxiliary power wiring is as follows:

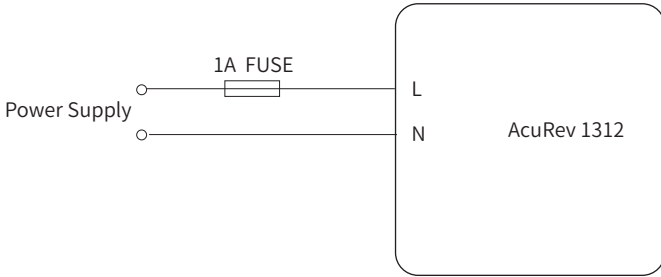

Figure 2-9 Power Supply Connections for Acurev 1310

The meter requires AWG22-16 as the wires to connect the power supply.

A fuse (typical 1A/250Vac) is suggested to be used when connecting the power supply to the meter.

Note: Check the power supply rating before wiring. Please confirm by reading the Power Supply information on the silver sticker at the side of the meter.

### 2.3.3 Voltage Input:

The maximum input voltage for the AcuRev 1310 series meter cannot exceed 400LN/690LL VAC RMS for three phase or 400LN VAC rms for single phase. The voltage input requires a 1A fuse.

Potential Transformer (PT) must be used for high voltage systems that are greater than the meters rated voltage. The rated secondary output from the PT is typically 100-120V. Please make sure to select an appropriate PT to maintain the measurement accuracy of the AcuRev 1310 series meter. When connecting using the WYE configuration wiring method, the PT's rated input or primary side rated voltage should be equal to or close to the phase voltage of the system to utilize the full range of the PT being used. When connecting using the Delta configuration wiring method, the PT's rated input or primary side rated voltage should be equal to or close to the line voltage of the system.

A fuse rated for 1A/600V should be used when connecting the voltage inputs to the meter.

The meter requires the wire size to be AWG22-14.

**Note:** Under no circumstances should the secondary of the PT be shorted. The secondary of the PT should be grounded at one end. Please refer to the wiring diagram section for further details.

### 2.3.4 Current Input:

Current Transformers (CTs) are required in most applications. The AcuRev 1310 series meter supports four CT input types, 5A/1A, 333mV, Rogowski coil (RCT) and mA (80/100/200). CTs must be used if the systems rated current is over 5A. The CT should be selected to maintain revenue grade accuracy of the system. The distance between CT and the meter should be as short as possible as the length of the CT leads will have an effect on the accuracy.

The meter requires AWG22-14 as the wire size to the current input terminals.

**Note:** *The secondary side of the CT should not be open circuit in any circumstance when the power is on. There should not be any fuse or switch in the CT loop. One end of the CT loop should be connected to the ground when 5A/1A output CTs.*

When using mV, RCT and mA CT's the secondary leads must not be grounded.

#### Vn Connection

Vn is the reference point of the AcuRev 1310 series meter voltage input. Low wire resistance helps improve the measurement accuracy. Different system wiring modes require different Vn connection methods. Please refer to the wiring diagram section for more details.

AcuRev 1310 series meter supports different wiring configurations for both three phase and single phase systems. Please read this section carefully before choosing the suitable wiring method for your power system.

In the AcuRev 1310 series meter please make sure that the wiring connection mode and the corresponding practical application in engineering are correct to ensure the measurement accuracy of meter. Here are some of the common installation methods, their respective diagrams and meter configurations for the AcuRev 1310 series meter.

- 1) Three Phase: 4 wire-connection: (Three Phase with a neutral)  
 Wiring mode 3LN. Three CT's needed for this connection.  
 Common voltages for this connection: 120V LN/208V LL, 240V LN/415V LL

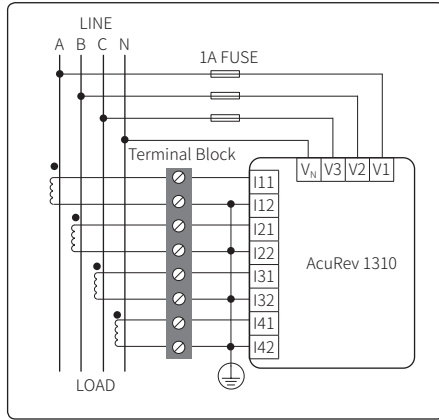

Figure 2-10a – AcuRev 1314 3LN wiring diagram using 5A/1A CTs

**Note:** AcuRev 1314-RCT current input does not support neutral current measurement

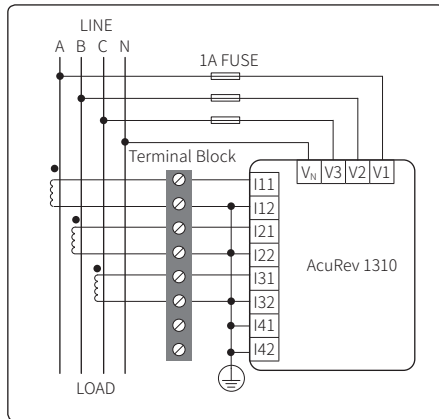

Figure 2-10b – **Acurev 1311, 1312, 1313** 3LN wiring diagram using 5A/1A CTs

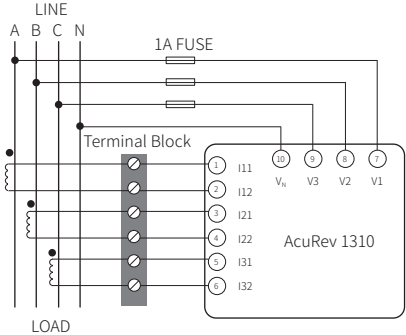

Figure 2-10c 3LN using 333mV, mA and Rogowski Coil CTs

2) Three Phase: 3 wire-connection (Three phase without a neutral)

The wiring mode is set to 2LL. Two CT's needed for this connection.

Note: Output of the CT is 5A/1A and mA.

With Potential Transformers (PTs) - PTs are required if the system voltage is higher than 690V LL. Instead of connecting the voltage lines directly to the meter, the voltage lines are connected to the meter using PTs. The PTs should be connected as shown below.

**Note:** Only two PTs are needed for this connection

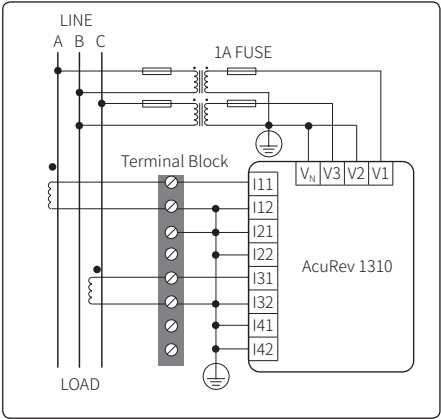

Figure 2-11a 2LL wiring diagram using 5A/1A CTs and PTs

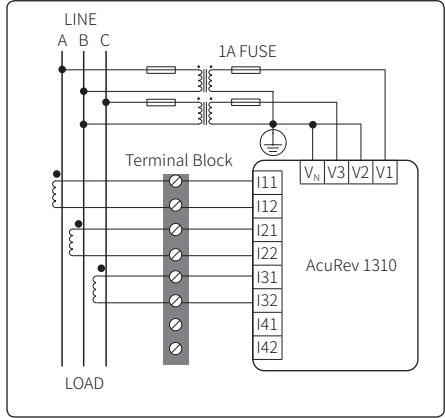

Figure 2-11b 2LL using 333mV, mA and Rogowski Coil CTs

Direct Connection, without PT's:

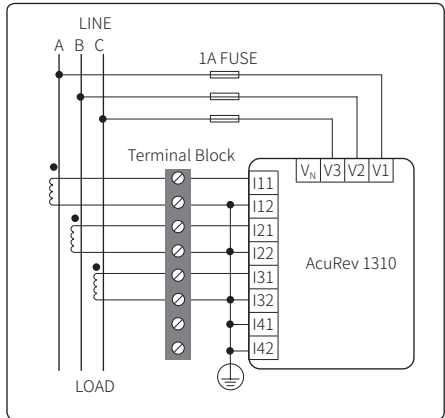

Figure 2-11c – 3LN– 3 phase delta no neutral wiring diagram using 5A/1A CTs



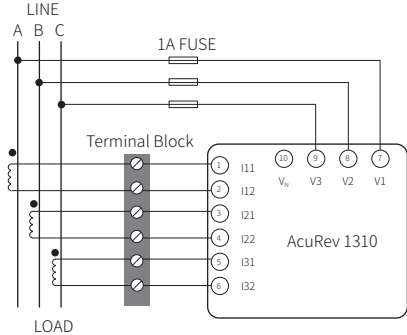

Figure 2-11d – 3LN- 3 phase no neutral wiring diagram using 333mV, mA and Rogowski Coil CTs.

3) Single Phase: 3 Lines (Single phase with 2 lines and a neutral)  
 The wiring mode is set to 1LL. Two CT's needed for this connection.

Common Voltage: 120V LN/240V LL

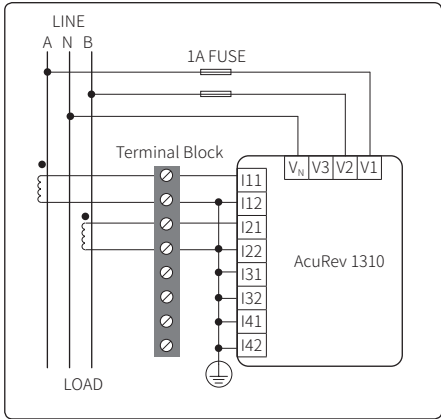

Figure 2-12a 1LL wiring diagram using 5A/1A and CT's

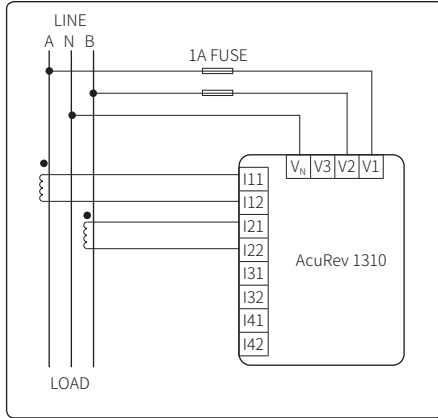

Figure2-12b 1LL Using 333mV, mA and Rogowski Coil CTs

4) Single Phase: 2 Lines (Single phase with one line and a neutral)  
 The wiring mode is set to 1LN. One CT needed for this connection.

Common Voltage for this connection: 120V

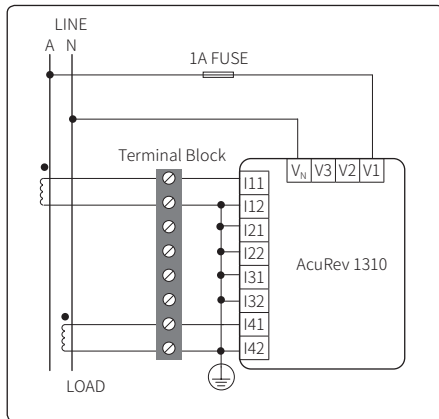

Figure 2-13a - **AcuRev 1314** Model 1LN using 5A/1A CT

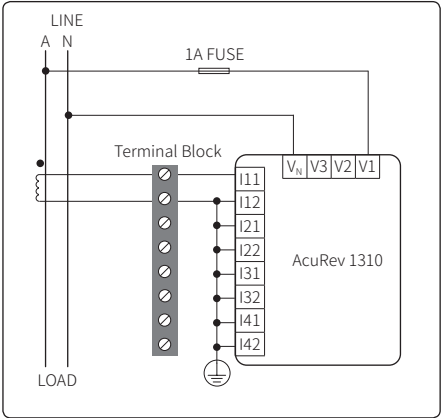

Figure 2-13b – AcuRev 1311, 1312, 1313 Model 1LN using 5A/1A CT

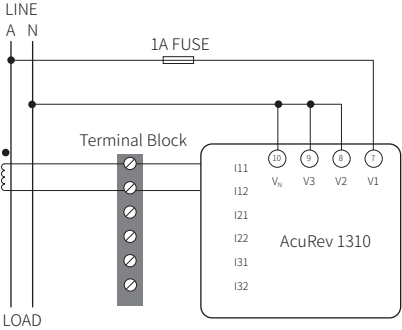

Figure 2-13c 1LN using 333mV, mA and Rogowski Coil CT

### 2.3.5 Relay Output Wiring Diagram

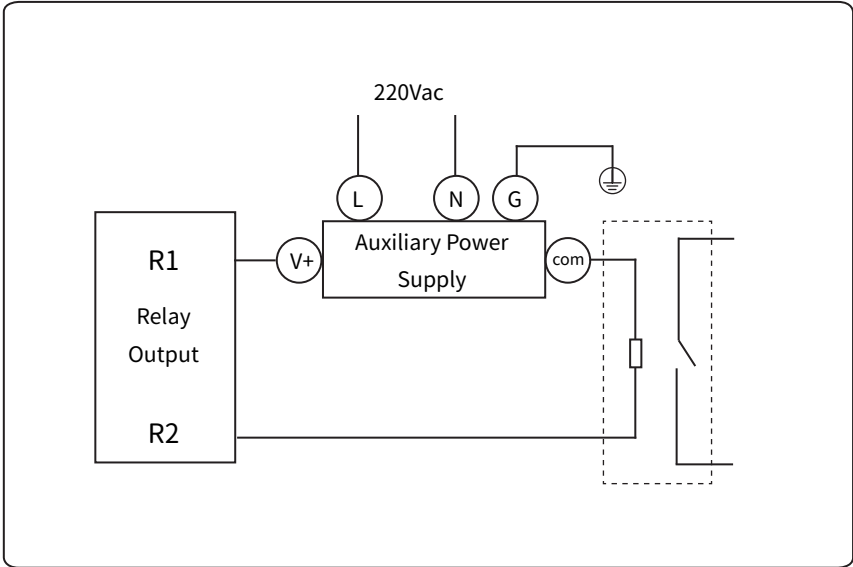

Figure 2-14 Relay Output Wiring Diagram

### 2.3.6 Communication

The AcuRev 1310 supports two different, *user-selectable, communication* protocols: **Modbus-RTU** and **BACnet MS/TP**. Modbus RTU is the factory default setting on the meter. Both protocols utilize the built-in RS485 port, which is located under the terminal cover on the front of the meter. The RS485 terminals are denoted as “**A**”, “**B**,” and “**S**”. “A” is the positive differential terminal, 'B' is the negative differential terminal, and 'S' is for connecting the shield of the shielded twisted pair cable.

The maximum distance of the cable should not exceed 1200m. This distance should be shorter if more devices are connected to the same communication link or if using a higher baud rate.

If the master device is equipped with an RS232 port instead of an RS485 port, an RS232-to-RS485 converter should be utilized.

In order to improve communication quality, note the following:

- A high-quality Shielded Twisted Pair cable is very important; AWG22 (0.6mm) or lower is recommended.
- Pay attention to "single-point earthing." This means that there is only one side for the shield to be connected to the ground in a communication link.
- Every A (+) should be connected to A (+) and every B (-) should be connected to B (-). Failure to make the proper connections can influence the network or even damage the communication interface.
- “T” type connection topology should be avoided. This means no new branches except from the starting point.
- Keep communication cables as far away as possible from sources of electrical noise.
- When several devices are connected in daisy chain to the same long communication line, a resistor (typical value 120- 300 Ohm, 0.25W) should be used at the end of the circuit (the last device of the chain).
- Only use RS232-to-RS485 or USB-to-RS485 converters with an optically isolated output and surge protection.

# *AcuRev 1310* DIN-Rail Power Meter

**3.1 Display Panel and Keys**

**3.2 Display Mode and Key Operations**

**3.3 Parameter Display and Key Operations**

**3.4 Settings and Operations**

**3.5 Meter Configuration**

**3.6 Energy Pulse Output**

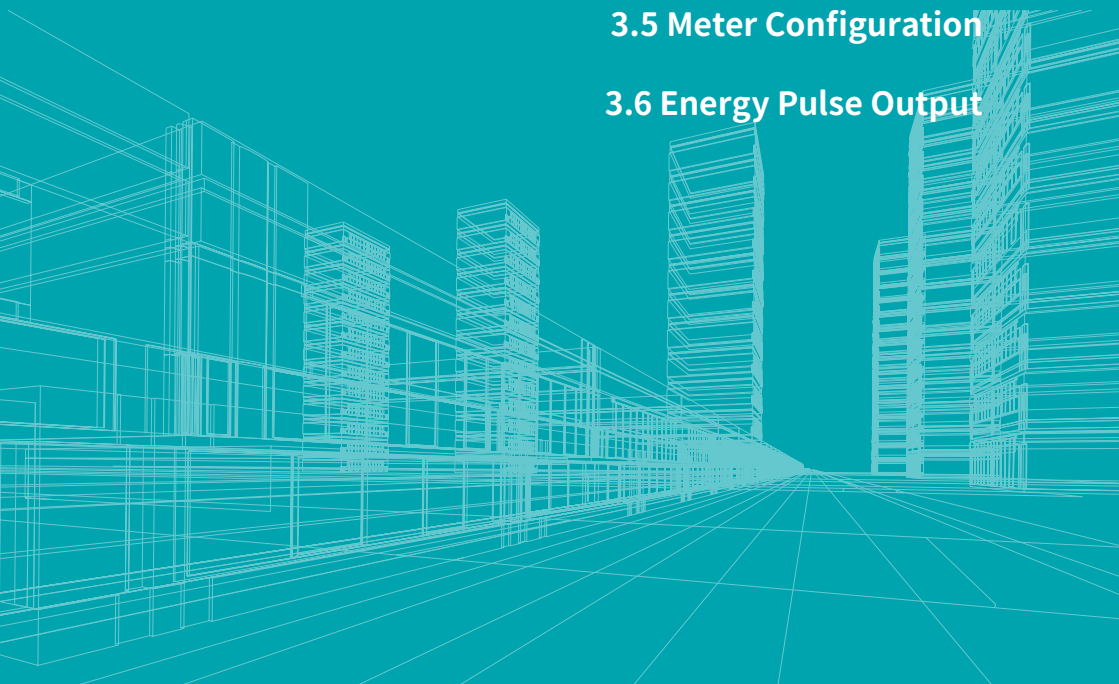

In this chapter, users will be introduced to the interface of the AcuRev 1310 meter as well as how to interact with the meter using the key on the display to read and configure parameters.

### 3.1 Display Panel and Keys

The AcuRev 1310 meter consists of a built-in LCD screen and a key (SCROLL key) for users to interact with the meter. Figure 3.1.1 shows the display of the AcuRev 1310 with all characters and number segments visible as a visual example only, they would not appear on one page. These symbols are explained in Table 3.1.

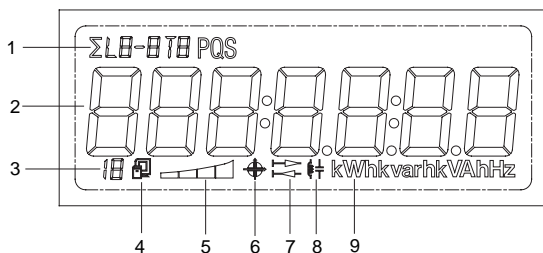







Figure 3.1.1

Table 1- Display icons

NO.	Content	Description
1	Description Area	To display what kind of parameter in the display area. To distinguish the power of conjunction, split phase, current, demand, parameter Settings, and so on.
2	Measurement parameter display area 7 segments can be displayed.	To display the main measurement parameters: Energy, Voltage, Current, Power, Frequency, Demand, Settings, Time.
3		Indicates All information mode.
4	Communication Icon 	No icon: No communication; One icon: Query sent; Two icons: Query sent and response received
5	Load size icon 	Displays in the analog way according to the load frequency
6	Four- quadrant reactive power display 	Indicates the first to fourth quadrant reactive power.
7		Import icon(right arrow): Displays the energy consumed Export icon(left arrow) displays the energy generated
8	Load type 	Inductance icon: Inductive load Capacitor icon: Capacitive load
9	unit	Unit of the parameter being displayed.

## 3.2 Display Mode and Key Operations

The LCD display of the AcuRev 1310 meter consists of three display modes:

- Important Parameter Display
- All Parameters Display
- Settings mode.

By default, the important parameter display shows the Consumed Active Energy (kWh) parameter.

### 3.2.1 Important parameter display mode:

The important parameter display mode is the default display mode of the meter. It will display the measurement parameters of the AcuRev 1310 series meter. Users only see the Consumed Active Energy (kWh) parameter unless additional parameters are added through the settings mode.

Users will be in this mode when they power on the meter or when they push the “SCROLL” key after a period of inactivity. Each measurement parameter in this mode will display on the screen for 6 seconds. When the “SCROLL” key is pressed in this display mode it will lock the current page for a minute and the backlight will remain on. Pressing the “SCROLL” key again will turn the next page and lock the display for another minute. After one minute of inactivity the display will continue operating normally by cycling through the enabled measurement parameters.

### 3.2.2 All parameter display mode:

The all parameters display will show all the parameters that the AcuRev 1310 meter supports as well as information about the meter. Pressing and holding the “SCROLL” key from the important parameter display mode will direct the user to the all parameter display mode. In this mode there will be a  displayed on the bottom row of the display to indicate the AcuRev 1310 is in all parameters display mode.

Pressing the "SCROLL" key will turn to the next page in the display. Once the user has cycled through all the parameters, pressing the "SCROLL" key again will take the user back to the first page.



### 3.2 Parameter Display and Key Operations

The following tables show the All Parameters Display for the different AcuRev 1310 Series Meters.

Table 3-2 All Parameters Display for **AcuRev 1311**

Page	Parameter
1	Voltage Wiring Check
2	Current Wiring Check
3	Meter Address
4	Hardware Version
5	Software Version
6	Date of Issue
7	Model Number
8	Imported Active Energy
9	Consumed Active Energy Phase A(kWh)
10	Consumed Active Energy Phase B(kWh)
11	Consumed Active Energy Phase C(kWh)
12	Voltage Phase A(V)
13	Voltage Phase B(V)
14	Voltage Phase C(V)
15	Current Phase A(A)
16	Current Phase B(A)
17	Current Phase C(A)
18	Total Current(A)
19	Total System Active Power
20	Active Power Phase A(kW)
21	Active Power Phase B(kW)
22	Active Power Phase C(kW)
23	Frequency(Hz)
24	Temperature
25	Meter Run Time
26	Load Run Time
---	End

Table 3-3 All Parameters Display for **AcuRev 1312**

Page	Parameter
1	Voltage Wiring Check
2	Current Wiring Check
3	Device Address
4	Baud Rate
5	Parity
6	Hardware Version
7	Software Version
8	Release Date
9	Model
10	Consumed Active Energy(kWh)
11	Consumed Active Energy Phase A(kWh)
12	Consumed Active Energy Phase B(kWh)
13	Consumed Active Energy Phase C (kWh)
14	Phase A Voltage(V)
15	Phase B Voltage(V)
16	Phase C Voltage(V)
17	Phase A Current(A)
18	Phase B Current(A)
19	Phase C Current(A)
20	Total Current(A)
21	System Active Power(kW)
22	Active Power Phase A(kW)
23	Active Power Phase B(kW)
24	Active Power Phase C(kW)
25	Frequency(Hz)
26	Temperature
27	Meter run time
28	Load run time
---	End

Table 3-4 All Parameters Display for **AcuRev 1313**

Page	Parameter
1	Voltage Wiring Check
2	Current Wiring Check
3	Device Address
4	Baud Rate
5	Parity
6	Hardware Version
7	Software Version
8	Release Date
9	Model
10	Consumed Active Energy(kWh)
11	Consumed Active Energy Phase A(kWh)
12	Consumed Active Energy Phase B(kWh)
13	Consumed Active Energy Phase C (kWh)
14	Phase A Voltage(V)
15	Phase B Voltage(V)
16	Phase C Voltage(V)
17	Phase A Current(A)
18	Phase B Current(A)
19	Phase C Current(A)
20	Total Current(A)
21	System Active Power(kW)
22	Active Power Phase A(kW)
23	Active Power Phase B(kW)
24	Active Power Phase C (kW)
25	Frequency(Hz)
26	Temperature
27	Meter run time
28	Load run time
---	End

Table 3-5 All Parameters Display for **AcuRev 1314**

Page	Parameter
1	Voltage Wiring Check
2	Current Wiring Check
3	Device Address
4	Baud Rate
5	Parity
6	Hardware Version
7	Software Version
8	Release Date
9	Model
10	Consumed Active Energy(kWh)
11	Consumed Active Energy Phase A(kWh)
12	Consumed Active Energy Phase B(kWh)
13	Consumed Active Energy Phase C (kWh)
14	Phase A Voltage(V)
15	Phase B Voltage(V)
16	Phase C Voltage(V)
17	Phase A Current(A)
18	Phase B Current(A)
19	Phase C Current(A)
20	Total Current(A)
21	System Active Power(kW)
22	Active Power Phase A(kW)
23	Active Power Phase B(kW)
24	Active Power Phase C(kW)
25	Frequency(Hz)
26	Temperature
27	Meter run time
28	Load run time
---	End

### 3.4 Settings and Operations:

#### 3.4.1 Settings Mode

The settings mode is where the user can perform most configurations for the AcuRev 1310 meter. To enter the settings press the “SET” key which is located under the meters terminal cover. Next the user will be prompted by a password screen.

To input the user password, users will use the “SCROLL” key to change the value of the flashing digit. The “SET” key is used to move between digits and to confirm the entered password when on the last digit.

After entering the correct password, the AcuRev 1310 will direct users to the device address configuration of the meter.

Note: Users will be redirected back to the important parameters screen after entering the password if the physical/electronic seal is enabled.

In the setting mode there will be an “S” in the top row followed by the setting page number. After a minute of inactivity in this mode, the meter will be redirected back to the important parameter display. If the “SCROLL” key is pressed and held, the meter will also be redirected out of the settings mode.

**Note:** The default password of the meter is 0000.

**Note:** The ‘SET’ key is located under the meters terminal cover.

In the settings mode, the following operations apply for the keys:

The “SET” key is used to enter edit mode of the setting and to confirm the setting change.

The “SCROLL” key is used to move to the next setting page and to change the value of the setting when in edit mode.

The following tables will show the Setting Display for the different AcuRev 1310 Series Meters.

Table 3-6 Setting Display for **AcuRev 1311**

Page	Parameter	Range
1	Device Address	1-247
2	Password	0000-9999
3	Real Time Metering Mode	1: Primary 2: Secondary
4	Voltage Wiring	3LN; 1LL; 1LN; 2LL
5	CT2	5A/1A(5A Current Input) 80mA/100mA/200mA(mA Current Input) 333mV RCT
6	CT1	1~50,000
7	PT2	50~400
8	PT1	50~1000000
9	Pulse Constant	1~60000
10	Pulse Width	20~100ms
11	Energy Decimal Places	0-3
12	Custom Data Display: Add	
13	Custom Data Display: Remove	
14	Wiring Check	On; Of
15	Current Direction A	0: Positive 1: Negative

Page	Parameter	Range
16	Current Direction B	0: Positive 1: Negative
17	Current Direction C	0: Positive 1: Negative

Table 3-7 Setting Display for **1312 (Modbus)**

Page	Parameter	Range
1	Protocol Selection	0: Modbus 1: BACnet
2	Device Address	1-247
3	Baud Rate	1200;2400;4800;9600;19200;38400
4	Parity	Even, Odd, None2, None1
5	Energy Pulse Output	
6	Reactive Power Calculation	
7	Password	0000-9999
8	Real Time Metering Mode	1: Primary 2: Secondary
9	Voltage Wiring	3LN; 1LL; 1LN; 2LL
10	CT2	5A/1A(5A Current Input) 80mA/100mA/200mA(mA Current Input) 333mV RCT
11	CT1	1~50,000
12	PT2	50~400
13	PT1	50~1000000
14	Pulse Constant	1~60000
15	Pulse Width	20~100ms
16	Energy Decimal Places	0-3
17	Custom Data Display: Add	
18	Custom Data Display: Remove	
19	Wiring Check	On; Of
20	Current Direction A	0: Positive 1: Negative
21	Current Direction B	0: Positive 1: Negative
22	Current Direction C	0: Positive 1: Negative

Table 3-8 Setting Display for **1312 (BACnet)**

Page	Parameter	Range
1	Protocol Selection	0: Modbus 1: BACnet
2	Device Address	1-247
3	Baud Rate	1200;2400;4800;9600;19200;38400
4	Max Info Frame	1~255
5	Device Instance	1~4194303
6	Reset	0: No 1: Yes
7	Energy Pulse Output	
8	Reactive Power Calculation	
9	Password	0000-9999
10	Real Time Metering Mode	1: Primary 2: Secondary

Page	Parameter	Range
11	Voltage Wiring	3LN; 1LL; 1LN; 2LL
12	CT2	5A/1A(5A Current Input) 80mA/100mA/200mA(mA Current Input) 333mV RCT
13	CT1	1~50,000
14	PT2	50~400
15	PT1	50~1000000
16	Pulse Constant	1~60000
17	Pulse Width	20~100ms
18	Energy Decimal Places	0-3
19	Custom Data Display: Add	
20	Custom Data Display: Remove	
21	Wiring Check	On; Of
22	Current Direction A	0: Positive 1: Negative
23	Current Direction B	0: Positive 1: Negative
24	Current Direction C	0: Positive 1: Negative

AcuRev 1313/1314 is the same as AcuRev 1312 (both Modbus and BACnet)

## 3.5 Meter Configuration

### 3.5.1 Initial Setup

The AcuRev 1310 series meters need to be configured correctly in order for it to measure data accurately.

For the initial meter setup, the wiring mode, PT and CT ratios need to be configured on the meter. Here are the steps to set these up from the meter display. Users must ensure that the lower terminal cover of the meter has been removed in order to gain access to the “SET” button.

- Once the terminal cover is removed, press the “SET” key to enter the settings mode.
- Users will then be prompted by a password screen. You can leave the password as its default value of “0000” if no password was previously configured. If a password was configured use the “SCROLL” and “SET” keys to enter in the password.
- The next screen that will appear is the “S-0-1 Addr”
- Press the “SCROLL” key until you get to the “S-09 Lt” screen(S-04 if AcuRev 1311). Select the correct voltage wiring mode. This will be based on your voltage connection. For example if your voltage connection is a three phase 4 wire connection, the correct voltage wiring mode would be 3LN.

- Press “SET” to enter edit mode.
- Press “SCROLL” to select the wiring mode.
- Press “SET” to confirm the setting.

**Note:** Refer to Section 2.3 Wiring for more details about wiring configurations.

- Press the “SCROLL” key to move to the CT2 page. This setting should already be configured to the secondary value of the CT. After this is confirmed, press the “SCROLL” key to move to the next page.
- The ensuing page will be “S-11” for setting the primary rating of the CT. If no CT's are being used, leave this as the default value and press “SCROLL” to move to the next page. If CT's are being used, enter in the primary rating of the CT here.
  - Press “SET” to enter the edit mode and to move to the next digit.
  - Press “SCROLL” to change the value of the digit.
  - Press “SET” to confirm the setting and move to the next page.
- The next page will correspond to the PT2 setting. If no PT's are being used, leave this setting as the default and press the “SCROLL” key to go to the next page. If you are using PT's, enter the secondary value of the PT here.
  - Press “SET” to enter the edit mode and to move to the next digit.
  - Press “SCROLL” to change the value of the digit.
  - Press “SET” to confirm the setting and move to the next page.
- The next page will be “S-13” for the primary rating of the PT if it is being used.
  - Press the “SET” key to enter edit mode and to move to the next digit.
  - Press the “SCROLL” key to change the value of the digit.
  - Press the “SET” key to confirm the setting and move to the next page.

Once all of the initial meter configurations are set, the meter should now begin to read data correctly.

## 3.6 Energy Pulse Output

The AcuRev 1310 series supports the transmission of energy pulses through the P1 and P2 terminals of the meter. The AcuRev 1310 series uses the KYZ output to transmit test pulses that are proportional to the accumulated energy that the meter is measuring.



The maximum output voltage and current of the pulse output circuit in the AcuRev 1310 series is 250V and 100mA respectively.

### Configuration

Ensure that the following configurations in the meter are correct to make certain the accuracy of the meter.

- Wiring Mode
- CT2
- CT1
- PT2
- PT1

To check these settings refer to section 3.5 in the meter configurations section of the manual.

With the above settings confirmed to ensure the meter will measure the voltage and current accurately, the next step is to configure the meter to output the desired number of pulses based on the required specification.

Make certain that you are in the settings mode. To get into the settings mode follow the procedure in section 3.5 of the manual.

- Once in the “Settings” mode, press the “SET” key to get to the “S-04 PULSE” page. This configuration is to enable the meter to output pulses based on the Active Energy (P) or the Reactive Energy (Q).
  - Press the “SET” key to modify the setting; the cursor should now flash.
  - Press the “SCROLL” key to select the type of energy to output.
  - Press the “SET” key to confirm the selection.
- Press the “SCROLL” key to get to the “S-13 Pn” page. This configuration will represent the number pulses (Pulse Constant) the meter will output per kWh/kvarh. This will be based on the required specification.
  - Press the “SET” key to modify; the first digit will begin to flash.
  - Press the “SET” key to move to the next flashing digit.
  - Press the “SCROLL” key to change the flashing digit’s number.
  - Press the “SET” key on the last digit to confirm all the changes after they have been made.

The following calculations can be used in order to calculate the value in the meter for the DO Pulse constant:

- First you will need to determine how many pulses are needed to represent 1 kWh or how many kWh will represent 1 pulse.

- In this procedure, we will assume that 1 pulse = 10kWh is what is needed. Then follow these steps:
  - Multiply the PT ratio and CT ratio i.e.  $PT1/PT2 * CT1/CT2$ .

Example: PT ratio of 6600V/120V, CT ratio of 2000:5A =>  $6600/120 * 2000/5 = 22,000$ .

**Note:** if no PTS were used, then enter the PT ratio as the default on the meter, i.e. 400/400. If the CT2: 333mV, RCT or 80/100/200mA, consider this as 1A for the calculation.

- Divide 10kWh by 22,000 i.e.  $(10/22000) kWh = (1/2200) kWh$ .
- This means that 1 pulse =  $(1/2200)kWh$ , therefore 2200 pulses = 1kWh

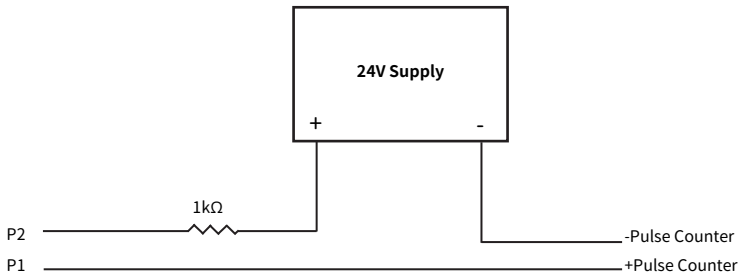

- Since we get 2200 pulse/kWh, enter 2200 as the pulse constant into the meter
  - Press “SCROLL” to get to the “S-14 PH” page. This configuration will represent the pulse width of the pulse that the meter will output. Put in the pulse width for the pulse output. The range is 20-100ms.

## Pulse Output Wiring

Figure 3-2 Pulse Output Wiring Diagram

- A 24V DC supply is required to power the circuit and should be connected to the P2 terminal of the meter.
- A 1 kilo ohm resistor is suggested to be used in series to limit the current to the P2 terminal (refer to Figure 3-2 above).
- The P1 terminal is connected to the positive terminal of the pulse counter.
- The negative terminal of the 24V DC supply is connected to the negative of the pulse counter.

With the pulse output circuit and settings configured the pulse output can be tested. Inject the meter with both voltage and current to ensure that the meter will accumulate energy and also output the pulses based on the above settings.

## Chapter 4 Functions Functions and Software

---

**4.1 Introduction to AcuRev 1310 Utility Software**

**4.2 Parameter Settings**

**4.3 Real Time Metering**

**4.4 Measurement Function**

**4.5 Event Logging**

**4.6 Alarm Function**

**4.7 Incorrect Connection Detection**

**4.8 Sealing Function**

**4.9 Device Information**

This chapter will introduce you to using some important functions. Many advanced functions cannot be performed through the meters display. Due to this we made the AcuRev 1310 Utility software. This chapter will introduce you to some of the software’s functions.

**Note:** Only the AcuRev 1312, 1313 and 1314 can be connected through the AcuRev 1310 Utility Software. The AcuRev 1311 is not supported.

## 4.1 Introduction to AcuRev 1310 Utility Software

The AcuRev 1310 series meters can be accessed through the AcuRev 1310 Utility Software. The software can be downloaded from the Accuenergy website under Downloads, or using the following link: <https://www.accuenergy.com/support/product-support-documents/>

The software can be used to read the meters measurements or to configure the meters settings. To connect to the software a USB-RS485 converter must be used.

**Note:** The AcuRev 1310 Utility Software is a Windows based software.

The following details the steps to connect the meter to the computer with the USB-RS485 converter.

To connect the following two wires should be connected from the USB-RS485 converter to the meter:

- 1) T/R+ from the converter to “A” on the AcuRev 1310 series meter
- 2) T/R- from the converter to “B” on the AcuRev 1310 series meter

The following figure shows the two wire connections.

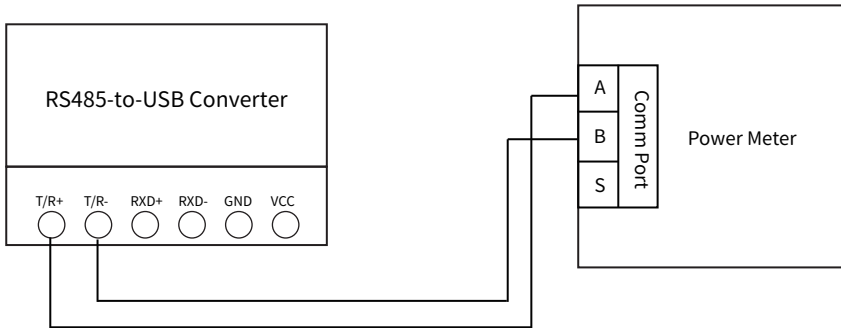

Figure 4-1 Connecting USB-RS485 converter to AcuRev 1310 Series Meter.

The Communication Port (COM Port) that the meter is connected to on the computer can be found from the “Device Manager” in Windows.

Use the following steps to get to the Device Manager on your Windows computer:

1. Open the Windows Start Menu.
2. Right Click on Computer and select Properties.
3. In the window that appears, select Device Manager from the left navigation panel.
4. In the Device Manager window, double click on Ports (COM&LPT) from the dropdown list.
5. Locate the USB Serial Port (COMx) information where the x is the port number to use. For example COM3.

Once the COM Port is found make note of it as it is used to connect to the software.

Once the software has been opened, users will be prompted to enter the correct COM port of the computer, baud rate, parity, the device address of the meter, and the device type (AcuRev 1312, 1313, 1314). Enter the settings and click ‘OK’ to connect the meter to the software.

**Note:** The baud rate, parity, and device address must be the same on the meter as well as the AcuRev Utility Software.

The following figure shows the screen when you first open AcuRev 1310 Utility Software.

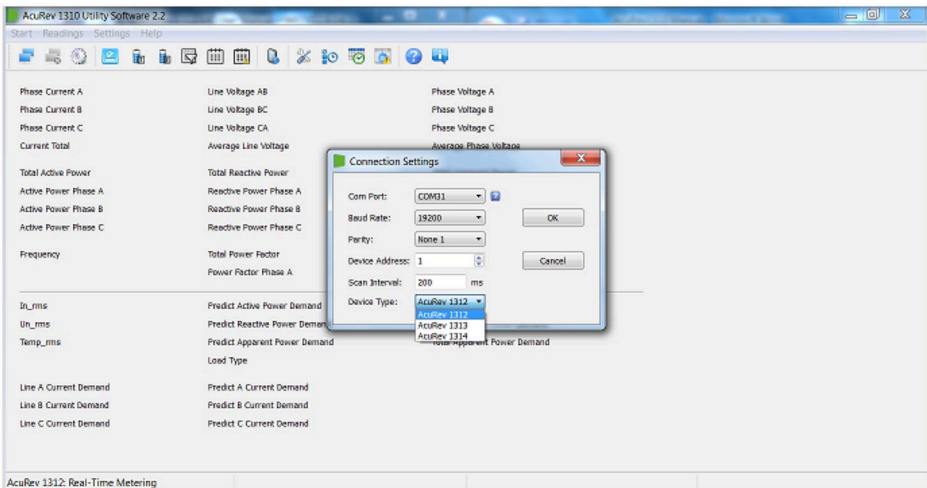

## 4.2 Parameter Settings

The AcuRev 1310 series meters requires general settings so that the meters can work according to the correct specification. The general settings can be found by clicking on the “Settings” menu on the main menu toolbar and selecting “General Settings” on the top menu bar of the software. The figure below shows the General Settings.

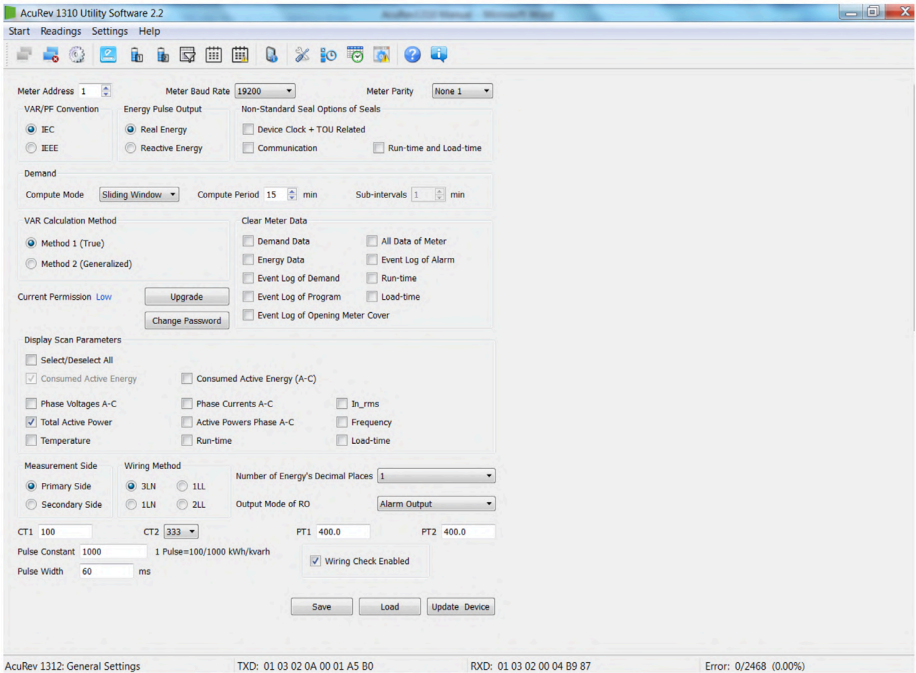

Figure 4-3 General Settings in the AcuRev 1310 Utility Software

**Note:** To ensure that any modifications in the General Settings takes place you must click on “Update Device” on the bottom of the General Settings page.

### 4.2.1 Wiring Method & CT/PT Settings

Users will need to select the correct “Wiring Method” (refer to section 2.3 for details). Users will also need to set the PT and CT ratio according to the practical use, if not set correctly this can lead to inaccurate measurements. “CT1” is the rated input of the CT being used, and “PT1”

and “PT2” correspond to the PT ratio of the PT used. The figure below shows these mentioned settings in the red boxes.

The screenshot shows a configuration window with the following settings:

- Measurement Side:** Primary Side (selected), Secondary Side
- Wiring Method:** 3LN (selected), 1LL, 1LN, 2LL
- Number of Energy's Decimal Places:** 2
- Output Mode of RO:** Control Output
- CT1:** 100
- CT2:** 333
- PT1:** 400.0
- PT2:** 400.0
- Pulse Constant:** 1000
- Pulse Width:** 60 ms
- Wiring Check Enabled:**

Buttons at the bottom: Save, Load, Update Device

Figure 4-4 the Wiring Method and CT/PT settings in the General Settings

### 4.2.2 Reactive Power Calculation:

$$\text{Real Reactive: } Q = \sqrt{(S^2 + P^2 + D^2)}$$

$$\text{Generally Reactive: } Q = \sqrt{(S^2 + P^2)}$$

### 4.2.3 Modbus Communication Options:

At the very top of the General Settings page users can configure the meters address, baud rate and parity for communication with the meter through Modbus. The red box in Figure 4-5 shows how it is displayed in the AcuRev 1310 Utility Software.

The screenshot shows the AcuRev 1310 Utility Software 2.2 interface with the following settings highlighted in a red box:

- Meter Address:** 1
- Meter Baud Rate:** 19200
- Meter Parity:** None 1

Other visible settings include:

- VAR/PF Convention:** IEC (selected), IEEE
- Energy Pulse Output:** Real Energy (selected), Reactive Energy
- Non-Standard Seal Options of Seals:** Device Clock + TOU Related, Communication, Run-time and Load-time

Figure 4-5 Meter address, baud rate, and meter parity settings on AcuRev 1310 Utility software

## 4.2.4 Energy Pulse Output

The AcuRev 1310 series supports the transmission of the pulses through the P1 and P2 terminals of the meter.

Active: P1, P2 terminal output pulse is based on the active energy pulse.

Reactive: the output pulse is based on the reactive power pulse.

You can see in the red box of the figure below the configuration for the Energy Pulse Output.

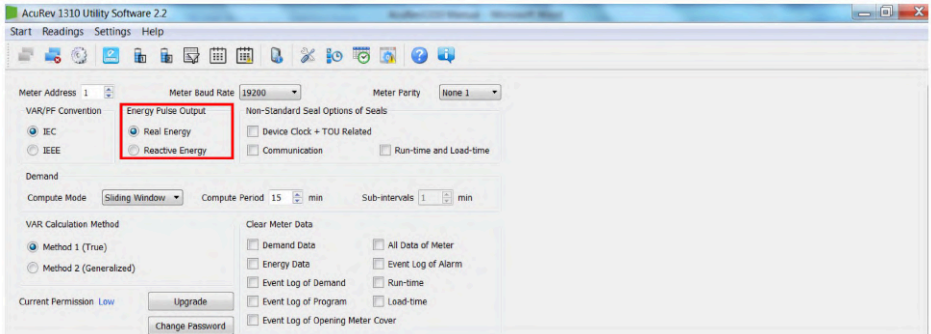

Figure 4-6 the Energy Pulse Output in the General Settings

The user will also have to enter the requirements for the pulse in the “Pulse Constant” and “Pulse Width” fields. The “Pulse Constant” is the number of pulses the user needs one pulse to represent in kWh/kvarh. The user can enter a value from 1-60000 for the pulse constant. The “Pulse Width” of the pulse is the duration it will last for. The user can enter a value from 20-100ms in this field. The figure below shows this in the red box.



Figure 4-7 the Pulse Constant and Pulse Width in the General Settings



## 4.2.5 Demand

Demand supports four kinds of calculation modes:

- Sliding Block Method

Set a 1-30min window time, which is the calculation time of demand. The window slides once per minute and updates the demand value at this time.

- Fixed Block Method

Set 1-30min as a demand calculation cycle. The whole cycle calculates the demand once. This means that the demand update time is equal to the demand calculation cycle.

- Rolling Block Method

Set 1-30min as a demand calculation cycle and 1 slip time. The demand cycle must be integer multiples of the slip time. It calculates 1 cycle's demand at the end of the slip time. The demand update time is equal to the slip time.

- Thermal Demand Method

Set 1-30min as a calculation cycle. In the whole cycle, the demand is calculated just once. This means that the demand update time is equal to the demand calculation cycle.

You can see the Demand calculations in the red box of the figure below. Under the dropdown menu in "Compute Mode" is where you can find the four different methods mentioned above.

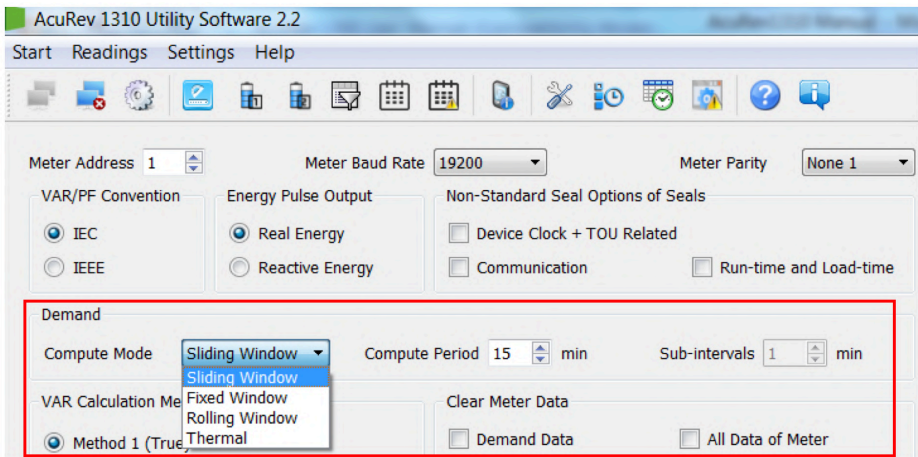

Figure 4-8 the Demand Calculation Modes in the General Settings of AcuRev1310 Utility Software

To View the demand parameter display click on ‘Readings’ on the main menu toolbar and then select ‘Demand’. Figure 4-9 shows the Demand display.

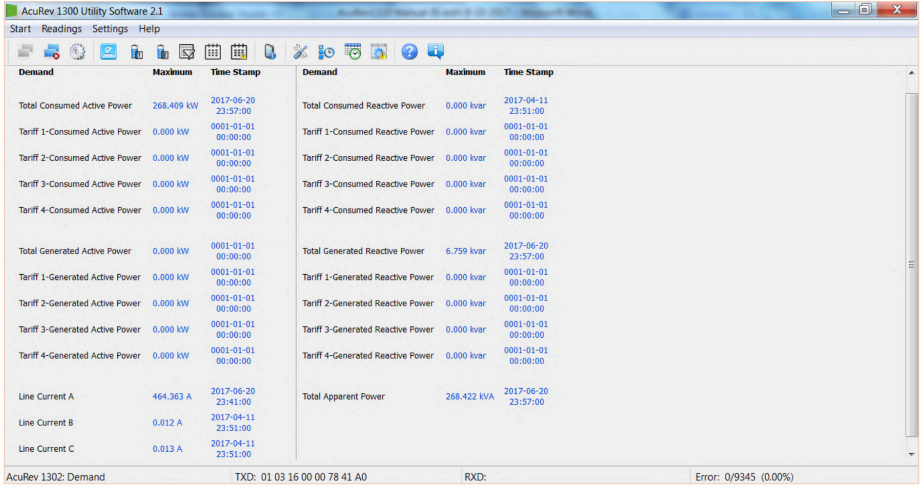

Figure 4-9 Demand Parameters Display

## 4.2.6 Sealing Option

- Choosing the “Device Clock + TOU related”, the corresponding content (Device Clock, TOU parameters, Daylight saving time parameters) can be sealed.
- Choosing “Run-time and Load-time” the content of the run and load time will be sealed.
- Choosing “Communication” the content of communication time will be sealed.

**Note:** To change the corresponding time it must occur once the seal is open.

The figure below shows the Sealing Options in the red box for the AcuRev 1310 Utility Software.

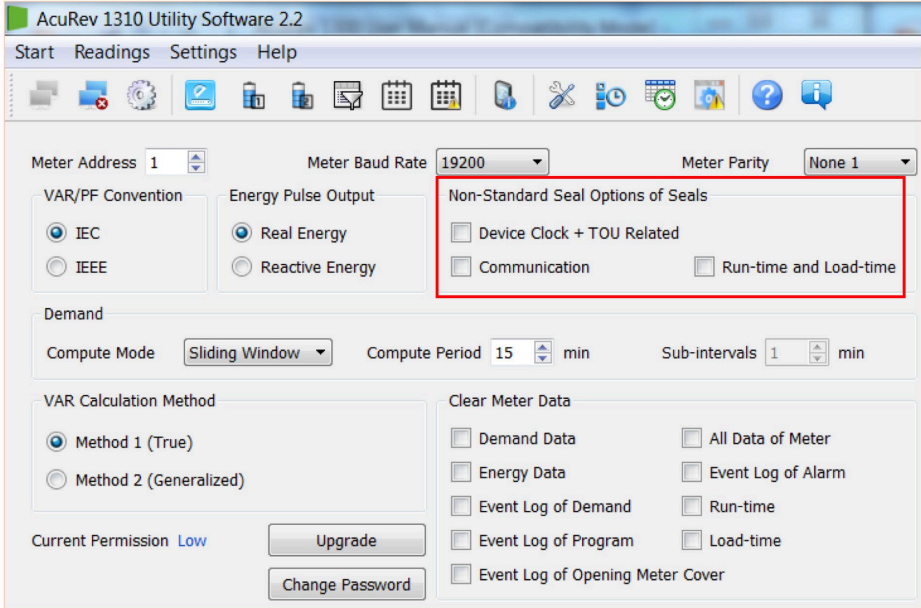

Figure 4-10 the Sealing Options in the General Settings

### 4.2.7 Communication Permission

The communication permission is divided into two settings either “low permission” or “high permission”.

- Low Permission: The important operations disabled. These operations include clear demand event record, programming event record, open cover event record, meter, energy data, and initial energy data.
- High Permission: This setting supports all functions.

**Note:** In the low permission you can update to high permission through updating the communication permission. After 30 minutes of updating to high permission, the meter would lower its permission to “low permission” automatically, to keep the meters safety.

The figure below shows the Communication Permission in the red box.

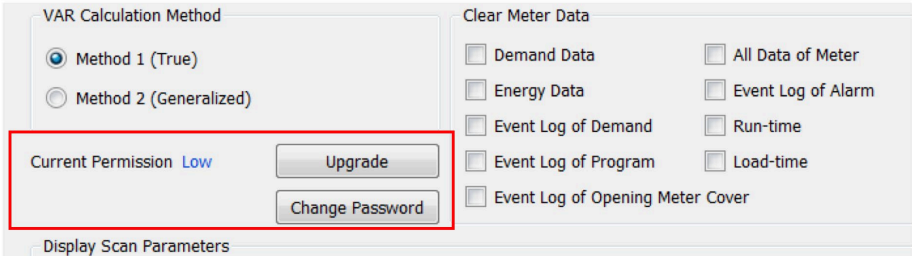

Figure 4-11 Communication Permission in the General Settings of the AcuRev 1310 Utility Software

### 4.2.8 Display Parameters

The user can add more parameters through the AcuRev 1310 Utility Software. Depending on the parameters chosen you will be able to view these parameters on the display by pressing the “SCROLL” key.

The figure below shows the Display Scan Parameters in the red box.

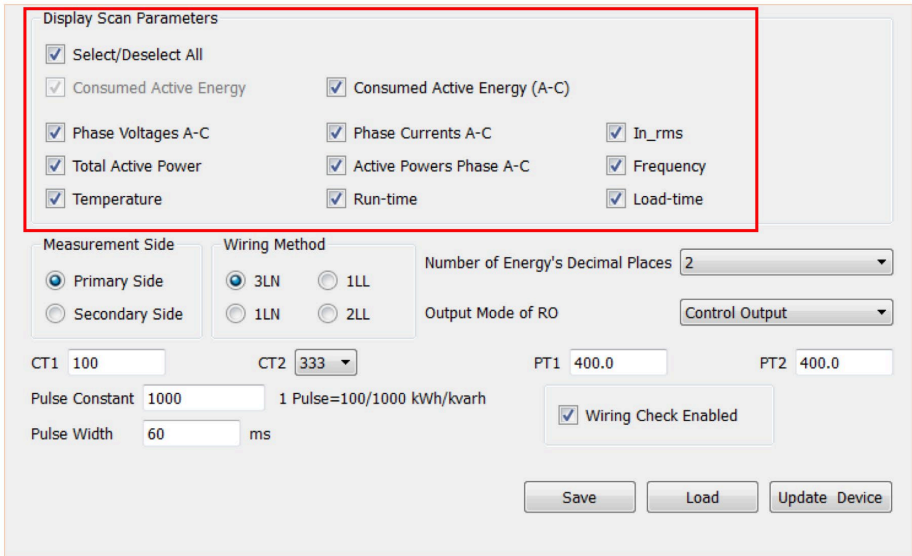

Figure 4-12 the Display Scan Parameters in the General Settings

## 4.2.9 Energy Decimal Places & RO output mode:

This setting is to change the number of decimal places in which the energy is read.

The RO (Relay Output) mode can be configured to control output or alarm output. The output can be configured according to the practical application.

You can see in the following figure the setting for the energy decimal place and RO output in the red box.

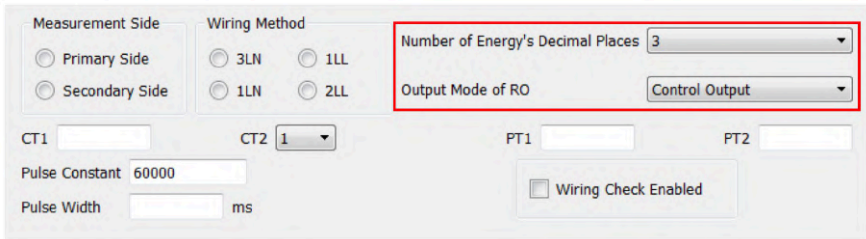

Figure 4-13 RO and Energy Decimal places in General Settings

## 4.3 Real-time Metering

Once connected successfully to the software, users will see the data readings appear in blue font beside each measurement parameter as shown in figure 4-14.

All metering parameters can be found by clicking on 'Readings' from the main menu toolbar and select 'Real-Time Metering'.

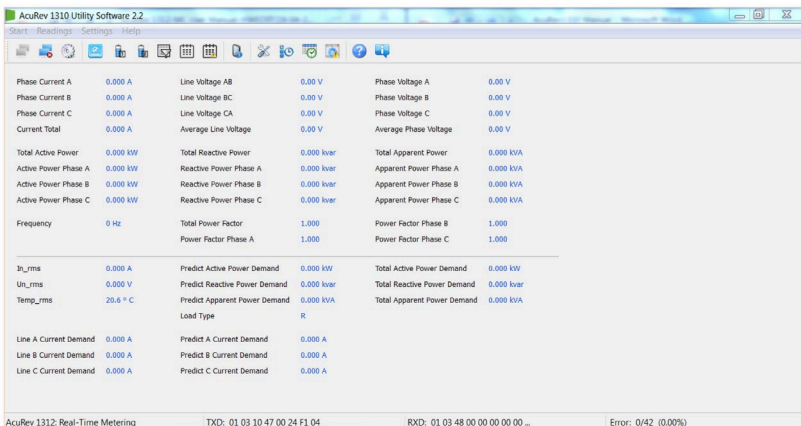

Figure 4-14 Real-Time Metering in the AcuRev 1310 Software

Users can also access the energy consumption by clicking on the “Readings” menu and selecting “Energy1”. You can refer to Figures 4-15 and 4-16 for assistance.

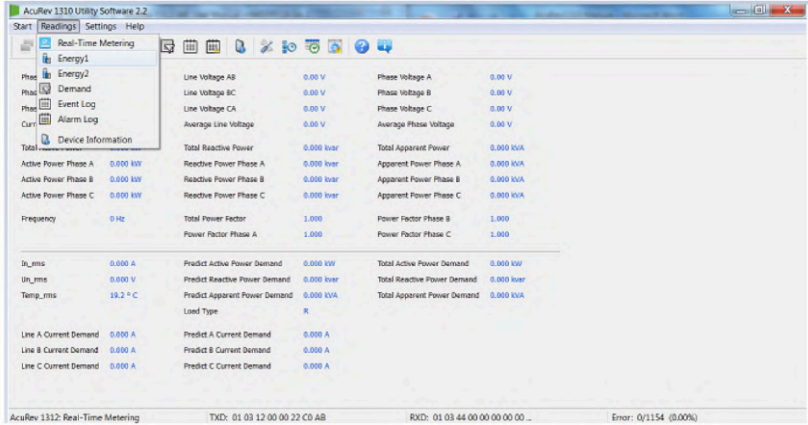

Figure 4-15 Navigating to Energy Readings

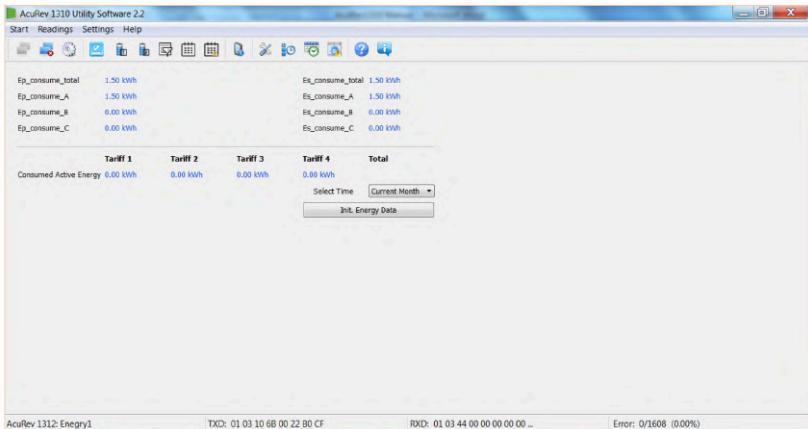

Figure 4-16 Energy Readings Page

Users will see all the energy that the meter has accumulated since the life of the meter or since the last time the energy readings were reset or cleared.

The lower half of the Energy1 page displays the consumed active energy readings that have been accumulated under the Time of Use (TOU) function of the meter.

**Note:** The Time of Use (TOU) function is only available on the AcuRev 1312, 1313, and 1314 models.

With the Time of Use function users can select the time period of the TOU energy as the current month, previous month or the past two months.

Users can also provide initial values for their AcuRev 1310 series models (only 1312, 1313, and 1314 applicable) to start to accumulate energy from. To do this, users must have sufficient permission, which can be obtained from the General Settings page.

## 4.4 Measurement Function

AcuRev 1310 series provides measurement of bi-directional energy accumulation. Real time energy can be initialized by changing the permission and sealing condition. The energy parameters supported:

- |                           |                               |
|---------------------------|-------------------------------|
| Consumed Active Energy    | Four-quadrant Reactive Energy |
| Generated Active Energy   | Consumed Reactive Energy      |
| Total Active Energy       | Generated Reactive Energy     |
| Net Active Energy         | Total Reactive Energy         |
| Consumed Apparent Energy  | Net Reactive Energy           |
| Generated Apparent Energy |                               |

These parameters can be located on the Energy 2 Readings page, which can be found on the 'Readings' menu and selecting 'Energy 2'. Figure 4-17 show how this will look on the AcuRev 1310 Utility Software.

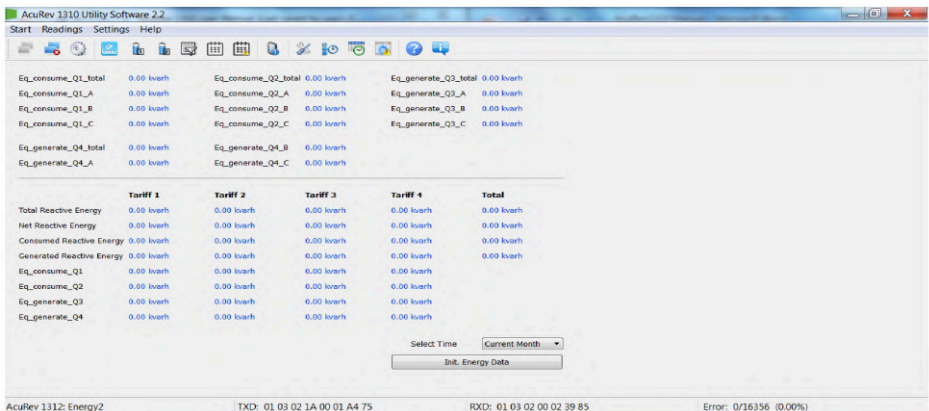

Figure 4-17 Energy 2 Readings Page

**Note:** The following settings for TOU (Time of Use) is only applicable to only certain AcuRev 1310 models which includes AcuRev 1312, 1313, and 1314 models.

## TOU Settings

Users can assign up to 4 different tariffs (sharp, peak, valley and normal) to different time periods within the day according to the billing requirements.

The meter will calculate and accumulate energy in different tariffs according to the meters internal clock timing and TOU settings.

The following figure shows the Time of Use Setting Display Page.

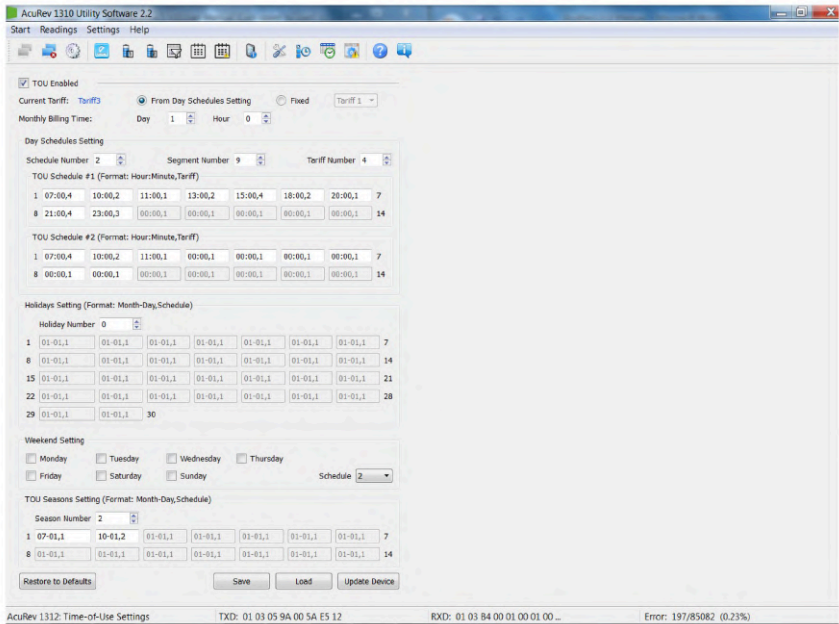

Figure 4-19 Time of Use Settings Page

TOU schedules can be configured up to 14 time segments, where each season can have its own TOU schedule. The user can customize the TOU calendar (including its tariffs, seasons, schedules and segments) according to different applications. To make sure that the TOU calendar is setup correctly, the meter will check the TOU settings according to the predefined rules (see below for “TOU Parameter Settings” for details). The TOU function will be disabled if the TOU calendar is set up incorrectly. If no errors are found in the calendar and the TOU function is enabled, TOU energy accumulation will commence.



### TOU Parameter Settings:

a. Season Settings: The maximum number of Seasons is 14, where each Season can have its own TOU schedule.

**Note:** *The seasons should be entered as an integer from 1-14 and should also be entered in chronological order.*

b. Schedule Settings: You can have a maximum of 8 schedules, where each schedule can be divided up into 14 time segments.

c. Segment Settings: You can have a maximum of 14 segments, where each segment can have its own tariff.

d. Tariff setting: There is a maximum of 4 tariffs. The four tariffs are sharp, peak, valley, and normal. They are represented by number 1-4 respectively (1: sharp, 2: peak, 3: valley, 4: normal). If the parameter is set as 2 then only the first 2 tariffs (sharp and peak) will be available.

e. Weekend Settings: In this section you can set up the schedule number according to weekends to assign a weekend schedule. Refer to Figure 4-20.

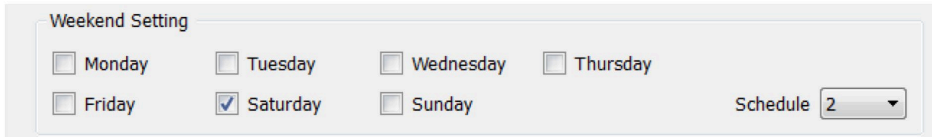

The image shows a configuration panel titled "Weekend Setting". It contains seven checkboxes for the days of the week: Monday, Tuesday, Wednesday, Thursday, Friday, Saturday, and Sunday. The Saturday checkbox is checked, while all others are unchecked. To the right of the checkboxes is a "Schedule" dropdown menu with the number "2" selected.

Figure 4-20 Weekend Setting in TOU configurations page

f. Holiday Setting: You can set up to a maximum of 30 holidays

**Note:** *If the holiday and weekend schedule number is set as 0, it means holidays are unavailable. If the weekend and holidays are overlapped, the holiday overrides the weekend settings since the holiday has a higher priority.*

### 4.4.1 TOU Seasons

Fill in the appropriate slots in the TOU (Time of Use) Seasons based on the number in the "Season Settings". If the "Season Settings" is set to 2 then only the first 2 slots of the "TOU Seasons" must be filled in.

**Note:** *If the slot is filled inappropriately then the TOU function will be disabled*

- The start date into the TOU Season slot is in the following format: “MM-DD-ID”
  - MM stands for month
  - DD stands for date
  - ID represents the TOU schedule (1-8)

**Note:** *The dates should be organized in chronological order (The earliest date comes first and the later date follows). Entering the dates in the wrong order will cause the TOU function to be disabled*

## Holidays

Fill in the appropriate slots under the “Holidays” setting based on the number in the “Holiday Setting”. If the “Holiday Setting” is set as 3 then only the first 3 slots of the “Holidays” must be filled in otherwise the TOU function will be disabled.

- Enter the date of the Holiday in the Holiday schedule slot in the following format “MM-DD-ID”
  - MM stands for month
  - DD stands for date
  - ID represents the TOU schedule(1-4)

**Note:** *The dates of the Holiday schedules do not need to be organized in chronological order.*

## TOU Schedules

Each TOU schedule is represented by a 24 hour cycle. Fill in the appropriate slots in the TOU schedule based on the number in the “Schedule Settings”. If the “Schedule Setting” is set as 8 then all of the “TOU Schedules” must be filled in.

The amount of slots to fill in each TOU Schedule depends on the “Segment Setting” parameter. If the “Segment Setting” parameter is set as 3 then the first 3 slots in each TOU Schedule must be set, otherwise the TOU function will be disabled.

- Enter the start time into the TOU Schedule slot in the following format “HH-MM-ID”
  - HH stands for hour in 24 hour format
  - MM stands for minutes
  - ID represents the tariff to follow (1-8)

The time should be organized in chronological order (The earliest time comes first and the later time follows).

**Note:** *Entering the time in the wrong order will cause the TOU function to be disabled*

## 4.4.2 Daylight Saving Time (DST)

There are two types of formats that the Daylight Savings Time can be enabled as:

1. Fixed date option:

If you choose a fixed date option, you set the format according to a fixed date for the DST switch, in the format of month/ day/ hour/ minute/ adjust time (in minutes).

2. Non-Fixed date option: If you choose the non-fixed option, the DST will be implemented by which day of the week, with the format as month/ which day/ which week/ hour/ minute/ adjust time (in minutes).

Setting the DST will cause the meter to automatically switch to and from daylight savings time. When the clock starts to run on daylight saving time, the meter will automatically adjust its clock to a time period in advance. While the clock is running to the end of daylight saving the meter will adjust its clock back to a pervious time period.

**Note:** Make sure to Click “Update Device” after making any changes in order to save the settings. If no errors are found then the TOU energy accumulation will begin.

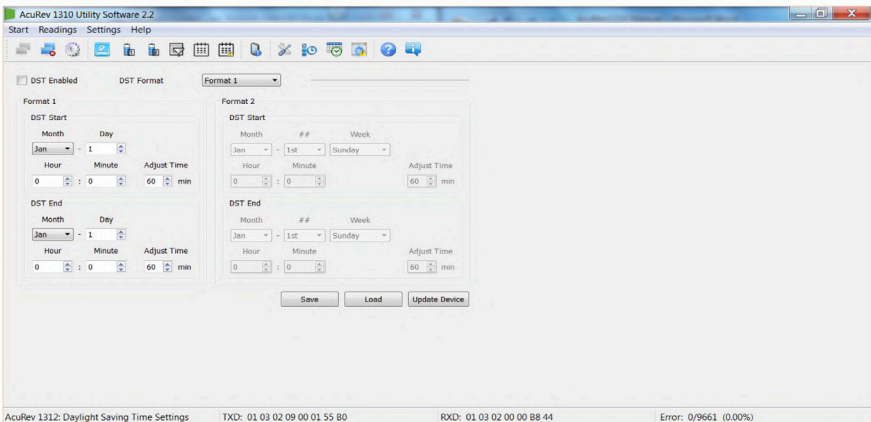

Figure 4-21 Daylight Saving Time Setting on AcuRev 1310 Utility Software

## 4.5 Event Logging

The AcuRev 1310 series supports event logging of important parameters and operation. The Event logging page can be found by clicking on the 'Readings' menu and selecting 'Event Log'. Figure 4-22 shows how the Event Log will look in the AcuRev 1310 Utility Software.

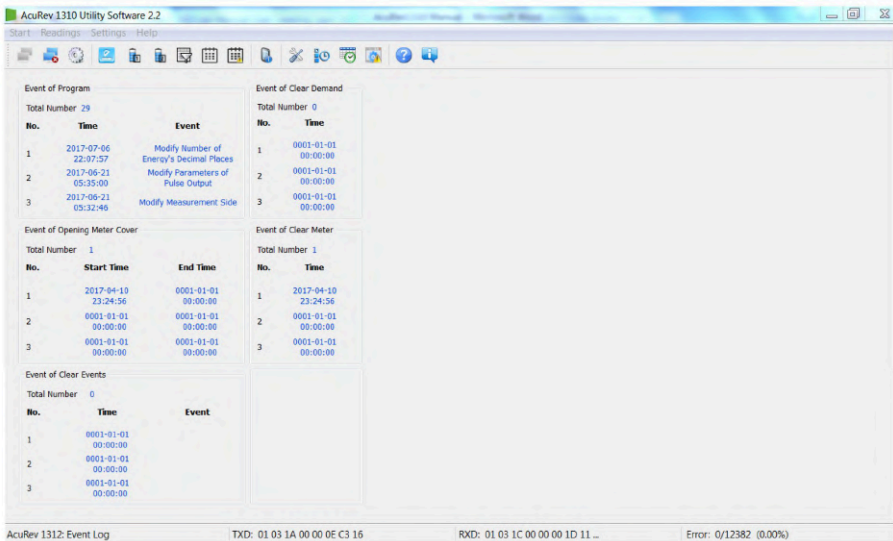

Figure 4-22 Event Log Page

The events that are logged include:

- **Event of Program**

This event records the programming time and programming event. When a programming event occurs several times within 5 minutes, the meter only records the first time.

Programming Flag	Programming Event
01	Meter address programming event
02	RS485 communication programming event
03	Reserved
04	Reserved
05	Energy pulse programming event
06	Demand related programming event
07	Reactive calculation method programming event

08	VAR/PF statue programming event
09	Change time programming event
100	Change energy base programming event
101	TOU parameter programming event
102	Daylight saving time programming event
103	Trend record programming event

Event of Program		
Total Number 29		
No.	Time	Event
1	2017-07-06 22:07:57	Modify Number of Energy's Decimal Places
2	2017-06-21 05:35:00	Modify Parameters of Pulse Output
3	2017-06-21 05:32:46	Modify Measurement Side

Figure 4-23 Event of Program in AcuRev 1310 Utility Software

- **Event of Clear Demand**

The meter will record when the Demand parameters are cleared. It records up to 3 groups of Clear Demand Events.

Event of Opening Meter Cover		
Total Number 1		
No.	Start Time	End Time
1	2017-04-10 23:24:56	0001-01-01 00:00:00
2	0001-01-01 00:00:00	0001-01-01 00:00:00
3	0001-01-01 00:00:00	0001-01-01 00:00:00

Figure 4-25 Event of Opening Meter Cover in AcuRev 1310 Utility Software

- **Event of Clear Meter**

In the Event of Clear Meter, it shows when the meter has had any data cleared. It supports 3 groups of meter clearance events.



Event of Clear Demand	
Total Number 0	
No.	Time
1	0001-01-01 00:00:00
2	0001-01-01 00:00:00
3	0001-01-01 00:00:00

Figure 4-26 Event of Clear Meter 4.6 Alarm Function

## 4.6 Alarm Function

The alarm function is used to monitor specific parameters, and when these parameters exceed a certain preset time limit, the event alarm will be triggered and stored in the AcuRev 1310 Utility Software. There can be a maximum of 20 records stored in the alarm log. To access the Alarm Settings click on “Settings” from the toolbar menu and then select “Alarm Settings”.

To set up the alarms, users must first select an alarming parameter, a condition, a delay time (ms), and an alarming output. Users can set a maximum of 12 alarms. Figure 4-27 shows you the Alarm Settings.

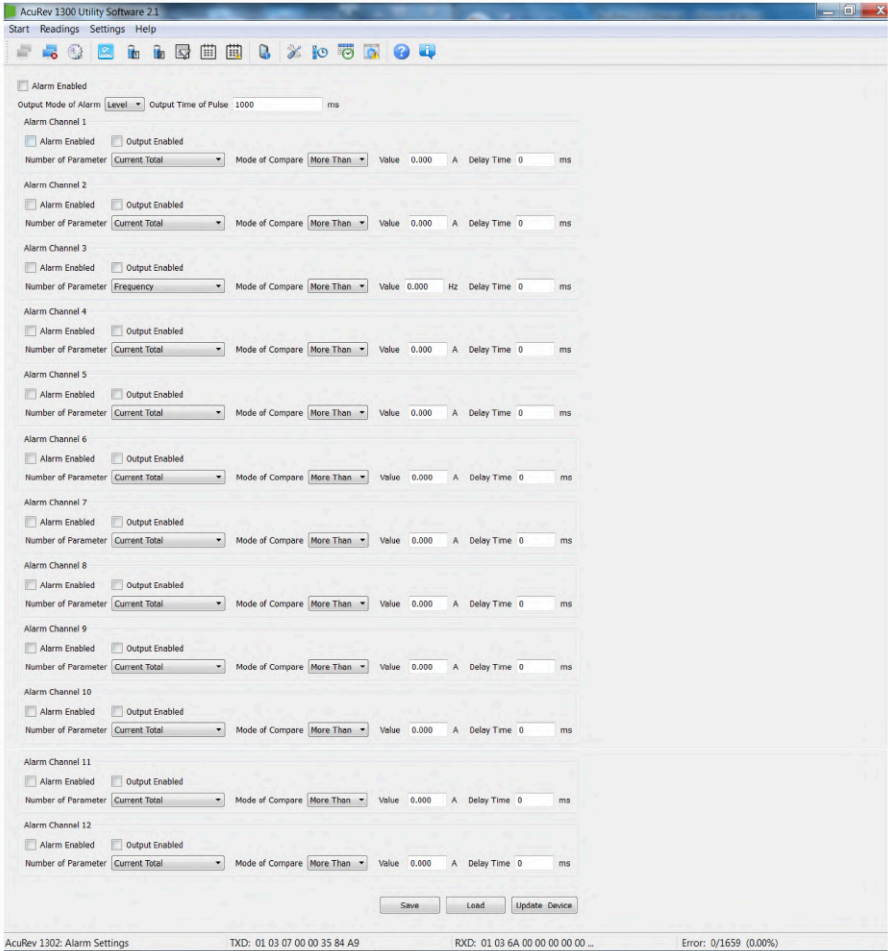

Figure 4-27 Alarm Settings Page on AcuRev 1310 Utility Software

## 4.6.1 Configuring the Alarm

- Enable the alarm function by checking off the “Alarm Enabled” box.
- Enable the preferred alarm channel(s) by checking off the “Alarm Enabled” box next to the channel.
- Under the “Alarm Channel” column select the parameter from the Real-time metering.
- Choose the required setting or condition for the alarm i.e. greater than (>), equal to (=), or less than (<).
- Enter the set point, where the set point is expressed by a percentage of the rated value.
- Enter in the desired Delay (ms) before alarm is triggered.
- Select the “Output Enabled” box if using a RO channel to be triggered when an alarm event occurs.

**Note:** Make sure to click on “Update Device” after making any changes in order to save the settings to the meter.

## 4.6.2 Reading the Alarm

To read the alarm log on the AcuRev 1310 Series Utility Software you click on the ‘Readings’ menu and select ‘Alarm Log’. The alarm log can be seen in Figure 4-28.

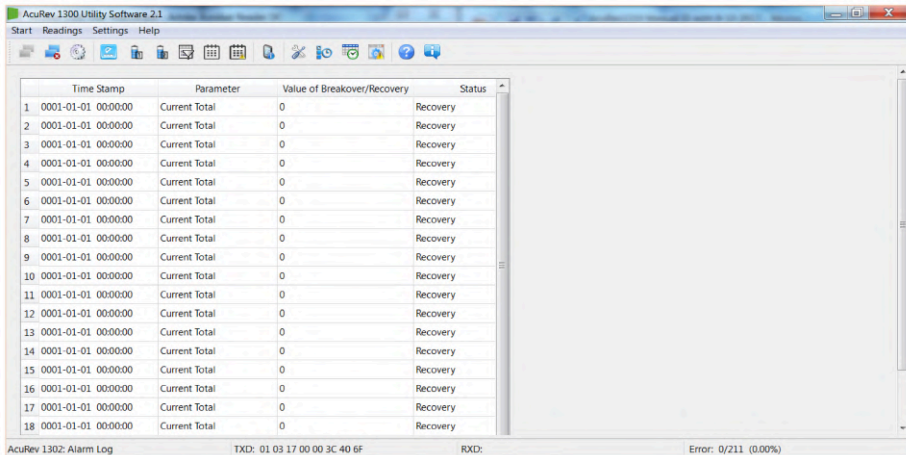

	Time Stamp	Parameter	Value of Breakover/Recovery	Status
1	0001-01-01 00:00:00	Current Total	0	Recovery
2	0001-01-01 00:00:00	Current Total	0	Recovery
3	0001-01-01 00:00:00	Current Total	0	Recovery
4	0001-01-01 00:00:00	Current Total	0	Recovery
5	0001-01-01 00:00:00	Current Total	0	Recovery
6	0001-01-01 00:00:00	Current Total	0	Recovery
7	0001-01-01 00:00:00	Current Total	0	Recovery
8	0001-01-01 00:00:00	Current Total	0	Recovery
9	0001-01-01 00:00:00	Current Total	0	Recovery
10	0001-01-01 00:00:00	Current Total	0	Recovery
11	0001-01-01 00:00:00	Current Total	0	Recovery
12	0001-01-01 00:00:00	Current Total	0	Recovery
13	0001-01-01 00:00:00	Current Total	0	Recovery
14	0001-01-01 00:00:00	Current Total	0	Recovery
15	0001-01-01 00:00:00	Current Total	0	Recovery
16	0001-01-01 00:00:00	Current Total	0	Recovery
17	0001-01-01 00:00:00	Current Total	0	Recovery
18	0001-01-01 00:00:00	Current Total	0	Recovery

AcuRev 1302: Alarm Log      TXD: 01 03 17 00 00 3C 40 6F      RXD:      Error: 0/211 (0.00%)

Figure 4-28 Alarm Log on AcuRev 1310 Series Utility Software



Referring to Figure 4-28, we can see that the alarm log features the time stamp which provides the time and date the alarm was triggered. The log also identifies which parameter was triggered (current, voltage, etc), and has a column for the value of Break Over which tells the user the amount they went over/under for that particular alarm setting. The last column of the alarm log is the status column. The alarm log can store up to 20 groups of alarm events.

### 4.7 Incorrect Connection Detection

The AcuRev 1310 series meter has a connection detection function. This function detects the connections or wiring to the meter based on the wiring mode configuration.

Table 4-2 Connection Detection

Bit15	Bit14	Bit13	Bit12	Bit11	Bit10	Bit9	Bit8
Reserve	Phase Voltage A Missing	Phase Voltage B Missing	Phase Voltage C Missing	Reserve	Phase Voltage A Wrong Connection	Phase Voltage B Wrong Connection	Phase Voltage C Wrong Connection
Bit7	Bit6	Bit5	Bit4	Bit3	Bit2	Bit1	Bit0
Reserve	Phase Current A Wrong Direction	Phase Current B Wrong Direction	Phase Current C Wrong Direction	Reserve	Phase Current A Wrong Connection	Phase Current B Wrong Connection	Phase Current C Wrong Connection

The very first screen in the All Parameters Display (see section 3.3 for details) is the voltage wiring check. On the LCD display, it will be in the following format:

U XXXXXX, where X is either '1' or '0'

- '0' represents the connection is correct
- '1' represents the connection is incorrect.

On the meter display digits 1~3 (from left to right) are would represent if a phase is not connected; Phase A Voltage missing, Phase B Voltage missing, Phase C Voltage missing. Digits 4~6 represent Phase A Voltage, Phase B, Phase C voltage being connected incorrectly.

The second screen in the All Parameters Display (see section 3.3 for details) is the current wiring check. On the meter display, it will be in the following format:

I XXXXXX, where X is either ‘1’ or ‘0’

- ‘0’ represents the connection is correct
- ‘1’ represents the connection is incorrect

On the meter display digits 1~3 (from left to right) represent Phase A CT, Phase B CT, Phase C CT being in the reverse direction . Digits 4~6 represent Phase A CT, Phase B CT, Phase C CT being connected incorrectly.

## 4.8 Sealing Function

The AcuRev 1310 series meter supports a sealing function. When the seal is open, the read write functions are available. When the seal is closed some of the meters functions which include parameters and optional parameters will be blocked and limited. These parameters can still be accessed by keys communication, but cannot be modified (Write function not available when seal is closed) when sealed status is present.

Address 209H corresponds to parameters blocked by the seal, which can be configured by users through communication. These settings will be valid only when the seal is in sealed status.

From 101H, we can check if the sealing state is opened or closed. When the seal status is open the address displays open sealing state. When the seal status is closed, the address displays closed sealing state, and the corresponding content will be blocked.

**Note:** ‘X’ means that these addresses will be blocked for keys and communication, and ‘-’ means this function is unavailable.

### Seal Standard Content:

Table 4-3 Seal Standard Content

Address	Parameter Description	Communication	Key
203H	Pulse Quantity choice	X	X
204H	Demand Calculation	X	-
205H	Demand Calculation Cycle	X	-
206H	Slip Time Demand Calculation	X	-
207H	Reactive Power Calculation Method	X	X
208H	VAR/PF Convention	X	-
209H	Seal Optional Content	X	-
213H	Remove Electric Meter Data (Except Demand Data)	X	-
216H	Measurement Side	X	X
217H	Wiring Mode	X	X
218H	CT2	X	X
219H	CT1	X	X

Address	Parameter Description	Communication	Key
220H	PT2	X	X
222H~223H	PT1	X	X
224H	Pulse Constant	X	X
225H	Pulse Width	X	X
226H	Energy Decimal Places	X	X

### Energy:

Table 4-4

Modbus Address (HEX)	Parameter Description	Communication	Key
900H-901H	Total Active Energy	X	-
902H-903H	Total Active Energy Tariff 1	X	-
904H-905H	Total Active Energy Tariff 2	X	-
906H-907H	Total Active Energy Tariff 3	X	-
908H-909H	Total Active Energy Tariff 4	X	-
91AH-90BH	Net Active Energy	X	-
90CH-90DH	Net Active Energy Tariff 1	X	-
90EH-90FH	Net Active Energy Tariff 2	X	-
910H-911H	Net Active Energy Tariff 3	X	-
912H-913H	Net Active Energy Tariff 4	X	-
914H-915H	Import Active Energy	X	-
916H-917H	Import Active Energy Tariff 1	X	-
918H-919H	Import Active Energy Tariff 2	X	-
91AH-91BH	Import Active Energy Tariff 3	X	-
91CH-91DH	Import Active Energy Tariff 4	X	-
91EH-91FH	Export Active Energy	X	-
920H-921H	Export Active Energy Tariff 1	X	-
922H-923H	Export Active Energy Tariff 2	X	-
924H-925H	Export Active Energy Tariff 3	X	-
926H-927H	Export Active Energy Tariff 4	X	-
928H-929H	Total Reactive Energy	X	-
92AH-92BH	Total Reactive Energy Tariff 1	X	-
92CH-92DH	Total Reactive Energy Tariff 2	X	-
92EH-92FH	Total Reactive Energy Tariff 3	X	-
930H-931H	Total Reactive Energy Tariff 4	X	-
932H-933H	Net Reactive Energy	X	-
934H-935H	Net Reactive Energy Tariff 1	X	-
936H-937H	Net Reactive Energy Tariff 2	X	-
938H-939H	Net Reactive Energy Tariff 3	X	-
93AH-93BH	Net Reactive Energy Tariff 4	X	-
93CH-93DH	Import Reactive Energy	X	-

Modbus Address (HEX)	Parameter Description	Communication	Key
93EH-93FH	Import Reactive Energy Tariff 1	X	-
940H-941H	Import Reactive Energy Tariff 2	X	-
942H-943H	Import Reactive Energy Tariff 3	X	-
944H-945H	Import Reactive Energy Tariff 4	X	-
946H-947H	Export Reactive Energy	X	-
948H-949H	Export Reactive Energy Tariff 1	X	-
94AH-94BH	Export Reactive Energy Tariff 2	X	-
94CH-94DH	Export Reactive Energy Tariff 3	X	-
94EH-94FH	Export Reactive Energy Tariff 4	X	-
950H-951H	Apparent Energy	X	-

**Sealed Nonstandard Parameters**

Table 4-5

Address	Parameter	Communication	Key
300H	Clock: Year	X	X
301H	Clock: Month	X	X
302H	Clock: Date	X	X
303H	Clock: Hour	X	X
304H	Clock: Minute	X	X
305H	Clock: Second	X	X
306H	Clock: Week	X	X

**Note:** When the seal is closed, standard time is valid within plus or minus 5 minutes, it will be invalid if not in this range.

Table 4-6

Address	Parameter Description	Communication	Key
TOU Related Parameters			
402H-40EH	Time-Division Energy Setting Parameter 1	X	-
420H-5F3H	Time-Division Energy Setting Parameter 2	X	-
Daylight Saving Time Related Parameters			
350H-367H	Daylight Saving Time Related Parameters	X	-

### 4.9 Device Information

All the information regarding the meter can be found by clicking on the “Readings” on the main menu toolbar and selecting “Device Information”. Figure 4-3 shows the Device Information page.

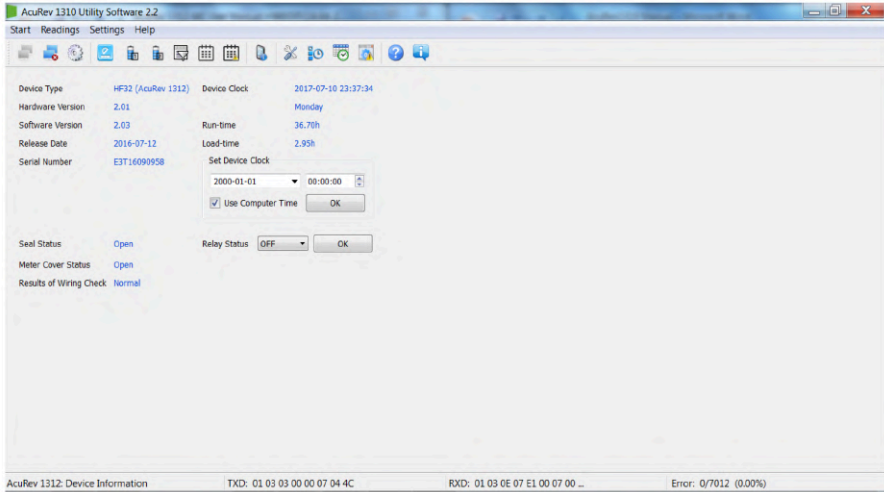

Figure 4-29 Device Information Page

Device Information such as hardware and software version of the meter can be found on this page. The Serial number and the seal status can also be located here. It is important to note that when the Seal Status is set to “Closed”, the user will be unable to make any configurations to the meter.

Users can also configure the device clock of the meter from this page to the time of the computer the meter is connected to or give it any other specific time.

# Chapter 5: Communication

---

## 5.1 Modbus Protocol Information

## 5.2 Communication Format

## 5.3 Application Details



This chapter introduces users on how to communicate with the AcuRev 1310 Series meter through the Modbus communication protocol. Knowledge of the Modbus communication protocol would be beneficial for users who read this chapter.

The chapter's contents include the Modbus protocol, communication format, and application of the AcuRev 1310 series meter.

## 5.1 Modbus Protocol Information

### 5.1.1. Transmission Mode

The mode of transmission defines the data structure within a frame and the rules used to transmit data.

Coding System	8 bit
Start Bit	1 bit
Data Bits	8 bit
Parity	No parity/ odd parity/ even parity
Stop bit	1 bit or 2 bit
Error checking	CRC

### 5.1.2. Frame

When the data frame reaches the AcuRev 1310 series meter (slave device), the meter removes the data frame's header, and reads the data. If there is no error, then the meter will implement the data's task. Once the task is completed, the meter will put its own data with the acquired header and send back the frame to the master device that queried the meter. The response data frame contains the address, function, data and CRC check. An error will cause the response to fail.

Table 5-1 Data Frame Format

Address	Function	Data	Check
8-Bits	8-Bits	N x 8-Bits	16-Bits

#### Address Field

The address field is the data at the start of the frame. It is composed of 8 bits (1 byte) and corresponds to the device address. It has a decimal value ranging from 1-247.

The master device addresses the slave device by placing the slave device address in the address field of the message. When the slave sends its response, it places its own address in the address field of response to let the master know which slave is responding.

**Function Field**

When a query is sent from the master to a slave device, the function code field tells the slave what kind of action to perform.

Table 5-2 Function Code

Function Code	Meaning	Action
03	Read Holding Register	Obtain current value of 1 or more registers
16	Preset register	Set value of 1 or more register
01	Reading Relay RO Status	Get the current state of the relay of the RO Output (ON/OFF)
05	Control relay RO state	Control relay RO Output state (ON/OFF)

**Data Field**

The data field contains the data that the slave device needs in order to complete the request. This data may be a numerical value, address or settings. For example, the function code tells the slave device to read one register, however the data field specifies readings from which register and how many registers to read.

**Error Check Field**

This field allows for error checks to be performed by both master and slave devices. Sources of errors such as electrical noise and other interferences can cause the data to be changed while it is being transmitted from one device to another. The error check ensures that the master or slave devices do not respond to the distorted data during the transmission. The error check rule used is the bit Cyclic Redundancy Check (CRC16).

**5.2 Communication Format**

Table 5-3 Protocol Illustration

Addr	Fun	Data start register hi	Data start register lo	# of registers hi	# of registers lo	CRC16 Hi	CRC16 Lo
06H	03H	00H	00H	00H	21H	84H	65H

Addr: Slave device address

Fun: Function code

Data start register hi: High byte of starting register address

Data start register lo: Low byte of starting registers address



Data # of registers hi: High byte of number of registers

Data of # of registers lo: Low byte of number of registers

### 1. Read Data (Function Code 03H)

This function code allows the user to obtain the measurement data from the AcuRev 1310 series meter.

Below is an example of a query for reading three of the AcuRev 1310 series energy parameters. The query is requesting the total active energy, tariff 1 active energy and tariff 2 active energy from the meter device address of 17. The data type of the energy parameters are double words. The data for each parameter will be in 2 registers where each register contains 2 bytes. The registers for the parameters to be polled in this example are 900H-901H, 902H-903H and 904H-905H respectively.

Query:

Table 5-4 Query frame of Reading Energy

Addr	Fun	Data start register hi	Data start register lo	# of registers hi	# of registers lo	CRC16 Hi	CRC16 Lo
11H	03H	00H	00H	00H	21H	84H	65H

Response:

The AcuRev 1310 series responds back to the master's query by responding with its slave device, function code, data and CRC check.

Below is the response from the AcuRev 1310 series meter for returning the total active energy (1.27kWh), tariff 1 energy (1.00 kWh) and tariff 2 energy (0.27kWh). When the values are returned to Modbus, they need to be scaled. The relationship for the energy data between the real value and the communication value is:

Real value = Communication value/100

Table 5-5 Response of Total Active Energy, Total Active Energy Tariff 1 Total, Active Energy Tariff 2

Addr	Fun	Byte Count	Data 1 hi	Data 1 low	Data 2 hi	Data 2 low	Data 3 hi	Data 3 low	Data 4 hi	Data 4 low
11H	03H	0CH	00H	00H	00H	7FH	00H	00H	00H	64H

Value hi	Value lo	Value hi	Value lo	CRC16 hi	CRC16 lo
00H	00H	00H	1BH	96H	8DH

**2. Preset/Reset Multi-Registers (Function Code 10H)**

Function code 10H allows the user to write the contents of meters registers such as system parameters and energy initialization.

Below is an example on writing a value to the meters total active energy (0.2kWh).

Table 5-6 Preset Energy Data

Addr	Fun	Byte Count	Data start register hi	Data start register lo	# of registers hi	#of registers lo	Byte Count
11H	10H	0CH	09H	00H	00H	00H	02H

Value hi	Value lo	Value hi	Value lo	CRC16 hi	CRC16 lo
00H	00H	00H	14H	CDH	30H

**5.3 Application Details**

**5.3.1 Data Types**

The data types supported by the AcuRev 1310 series meter have the following meanings:

Bit-binary value

Word-16 bit unsigned integer using one register that contains 2 bytes. The data range is 0-65535.

Int16-16 bit signed integer using one register that contains 4 bytes in total. The high bytes follow the low bytes in this data type. The data range is 0-4294897295.

Int32- 32 bit signed integer using two registers that contains 4 bytes in total. The data range is from 327698~32767.

Float-Single precision floating point number using two registers. The data range is-2147483648~22147483647.

**5.3.2 Relationship between Communication value and Real value**

The measurement values from the AcuRev 1310 series meter obtained through Modbus may not always be equal to the real value. The values may be scaled or a relationship may need to be applied.

**Note:** It is very important that the user is aware of these relationships when designing programs to poll the meter, otherwise the values may not be accurate.

Table 5-7 the relationship between communication value and real value

Parameter	Relationship	Unit
System Parameter settings and Status	The communication value equals the real value	----
Real-time Clock, Timestamps	The communication value equals the real value	----
Electrical measurement parameters		Electrical measurement parameters unit
PT1 & PT2	Real = Communication/10	----
Meter run time & Load time	Real = Communication/10	Hours

### 5.3.3 Parameter Address Table

Model 2, 3, 4 represents AcuRev1312, AcuRev 1313, and AcuRev 1314 respectively.

Read only block

03H- read command

Table 5-8 Meter Running State Display

MODBUS Address		Parameter Description	Data Type	Access Property	Range	Default	Model	Register Number
Hex	Decimal							
100H	256	The Result of Wiring Check	Word	R	Refer to Appendix "The Result of Wiring Check"			1
101H	257	Seals Status	Word	R	0x0A: Seal sealed Others: Seal opened			

### System Parameter

System parameters decides the devices working mode.

10H- read command

03H- write command

Table 5-9 System Parameters Address Table

MODBUS Address		Parameter Description	Data Type	Access Property	Range	Default	Model	Register Number
Hex	Decimal							
200H	512	Meter Address	Word	R/W	1-247	1	2~4	1
201H	513	Baud Rate	Word	R/W	1200; 2400; 4800; 9600; 19200; 38400	19200	2~4	
202H	514	Parity Bit Setting	Word	R/W	0: Even parity 1: Odd parity 2: No parity, Stop Bit 2 3: No parity, Stop Bit 1	3		
203H	515	Energy Pulse Output Type	Word	R/W	0: Active Power 1: Reactive Power	0	2~4	1
204H	516	Demand Calculation Method	Word	R/W	0: Sliding Window 1: Fixed Window 2: Rolling Window 3: Thermal	0	2~4	1
205H	517	Demand Calculation Period	Word	R/W	1-30 minutes	15	2~4	1
206H	518	Demand Calculation Slipping Time	Word	R/W	1-30 minutes	1	2~4	1
207H	519	Reactive Power Calculation Method	Word	R/W	0: True (sinusoidal) 1: Generalized (harmonics present)	0	2~4	1
208H	520	VAR/PF	Word	R/W	0: IEC 1: IEEE	0	2~4	1
209H	521	Sealed Parameters Selection	Word	R/W	Bit0: TOU set is Sealed or Not 1: valid of corresponding Selection 0: invalid of corresponding selection	0	2~4	1
20AH	522	Communication Revise Operation Authority	Word	R/W	0x02: Meter Reset, Event Reset, Write Energy Data 0x04: write Data(except Energy Data), Demand Peak reset Note: Register Revise needs correct Password, incorrect password is invalid.	0	2~4	1
20BH	523	Password	Word	W	0000-9999 Used for revise Communication Operation Authority, verify password when get new password		2~4	1
20CH	524	New Password	Word	W	0000-9999 Note: To get new password needs correct current password, incorrect current password in invalid.		2~4	1

20DH	525	Meter Data Reset	Word	W	Bit0: Reset Demand Record Bit1: Reset Event Record Bit2: Reset System Event Record Bit3: Reset Meter Opening Record Bit4: Reset Demand Event Bit5: Reset Alarm Event Bit6: Reset Meter Operation Time Bit7: Reset Time of Meter Operation with Load Bit8: Reset Meter Record (Reset Energy record, demand peak and happening time record, system event record, etc) 0:Reset 1: NO Note: Reset not valid without Communication Revise Operation Authority		2~4	1
20EH	526	Optional Display Symbol 1			Please see Appendix "Optional Display Symbol Setting"		2~4	1
20FH	527	Optional Display Symbol 2					2~4	1
210H	528	Parameter Measurement Side	Word	R/W	0: Primary Side 1: Secondary Side	0	2~4	1
211H	529	Wiring Mode	Word	R/W	0:3LN 1:2LL 2:1LL 3:1LN	0	2~4	1
212H	530	CT2 Value	Word	R/W	1; 5; 100; 200; 333	According to the order	2~4	1
213H	531	CT1 Value	Word	R/W	1~50000/5~50000	5	2~4	1
214H	532	CTN Value	Word	R/W	1~50000/5~50000	5	4	1
215H	533	PT2 Value	Word	R/W	50.0~400.0 (Communication value is 10 times of the real value)	220.0	2~4	1
216H -217H	534 -535	PT1 Value	Word	R/W	50.0~999999.9 (Communication Value is 10 times of the real value)	220.0	2~4	2
218H	536	Energy Pulse Constant	Word	R/W	1-60000	5000	2~4	1
219H	537	Energy Pulse Width	Word	R/W	20-100 ms	80	2~4	1
21AH	538	Energy Display Decimal	Word	R/W	0,1,2,3	1	2~4	1
21BH	539	Relay Operating Mode	Word	R/W	0: Relay Control 1: Alarm Output	0	2~4	1
21CH	540	Connection Detection Enable	Word	R/W	0: No Enable 1: Enable	1	2~4	1

Table 5-10 Real Time Reading Parameters

MODBUS Address		Parameter	Data Type	Property	Range	Default	# of registers
Hex	Decimal						
2000H-2001H	8192-8193	Total Current	float	R			2
2002H-2003H	8194-8195	Phase A Current	float	R			2
2004H-2005H	8196-8197	Phase B Current	float	R			2
2006H-2007H	8198-8199	Phase C Current	float	R			2
2008H-2009H	8200-8201	Phase Average Voltage	float	R			2
200AH-200BH	8202-8203	Phase A Voltage	float	R			2
200CH-200DH	8204-8205	Phase B Voltage	float	R			2
200EH-200FH	8206-8207	Phase C Voltage	float	R			2
2001H-2011H	8208-8209	Line Average Voltage	float	R			2
2012H-2013H	8210-8211	Line AB Voltage	float	R			2
2014H-2015H	8212-8213	Line BC Voltage	float	R			2
2016H-2017H	8214-8215	Line CA Voltage	float	R			2
2018H-2019H	8216-8217	Frequency	float	R			2
201AH-201BH	8218-8219	Total Active Power	float	R			2
201CH-201DH	8220-8221	Phase A Active Power	float	R			2
201EH-201FH	8222-8223	Phase B Active Power	float	R			2
2020H-2021H	8224-8225	Phase C Active Power	float	R			2
2022H-2023H	8226-8227	Total Apparent Power	float	R			2
2024H-2025H	8228-8229	Phase A Apparent Power	float	R			2
2026H-2027H	8230-8231	Phase B Apparent Power	float	R			2
2028H-2029H	8232-8233	Phase C Apparent Power	float	R			2
202AH-202BH	8234-8235	Total Reactive Power	float	R			2
202CH-202DH	8236-8237	Phase A Reactive Power	float	R			2
202EH-							2
202FH	8238-8239	Phase B Reactive Power	float	R			2
2030H-2031H	8240-8241	Phase C Reactive Power	float	R			2
2032H-2033H	8242-8243	Power Factor	float	R			2
2034H-2035H	8244-8245	Phase A PF	float	R			2
2036H-2037H	8246-8247	Phase B PF	float	R			2
2038H-2039H	8248-8249	Phase C PF	float	R			2
203AH-203BH	8250-8251	Phase Angle V1/V1	float	R			2
203CH-203DH	8252-8253	Phase Angle of V2 to V1 V1/V2 Phase Angle of V23 to V12 V12/V23	float	R			2
203EH-203FH	8254-8255	Phase Angle of V3 to V1 V1/V3 Phase Angle of V31 to V12 V12/V31	float	R			2

2040H-2041H	8256-8257	Phase Angle of I1 to V1 V1/I1 Phase Angle of I1 to V12 V12/I1	float	R			2
2042H-2043H	8258-8259	Phase Angle of I2 to V1 V1/I2 Phase Angle of I2 to V12 V12/I2	float	R			2
2044H-2045H	8260-8261	Phase Angle of I3 to V1 V1/I3 Phase Angle of I3 to V12	float	R			2
1208H-1209H	4616-4617	System Active Power Demand	float	R			2
120AH-120BH	4618-4619	System Reactive Power Demand	float	R			2
120CH-120DH	4620-4621	System Apparent Power Demand	Float	R			2
120EH-120FH	4622-4623	Phase A Current Demand	Float	R			2
1210H-1211H	4624-4625	Phase B Current Demand	Float	R			2
1212H-1213H	4626-4627	Phase C Current Demand	Float	R			2

### Energy: Function Code: 03H to Read; 10H to Write

Table 5-11 Real Time Energy Parameters

MODBUS Address		Parameter	Data Type	Property	Range	Default	# of registers
Hex	Decimal						
2046H-2047H	8262-8263	Total Active Energy Exported	Dword	R/W	0-9999999999kWh		2
2048H-2049H	8264-8265	Total Active Energy Exported Phase A	Dword	R/W	0-9999999999kWh		2
204AH-204BH	8266-8267	Total Active Energy Exported Phase B	Dword	R/W	0-9999999999kWh		2
204CH-204DH	8268-8269	Total Active Energy Exported Phase C	Dword	R/W	0-9999999999kWh		2
204EH-204FH	8270-8271	Total Active Energy Imported	Dword	R/W	0-9999999999kWh		2
2050H-2051H	8272-8273	Total Active Energy Imported Phase A	Dword	R/W	0-9999999999kWh		2
2052H-2053H	8274-8275	Total Active Energy Imported Phase B	Dword	R/W	0-9999999999kWh		2
2054H-2055H	8276-8277	Total Active Energy Imported Phase C	Dword	R/W	0-9999999999kWh		2

# AcuRev 1310 DIN-Rail Power Meter

MODBUS Address		Parameter	Data Type	Property	Range	Default	# of registers
Hex	Decimal						
2056H-2057H	8278-8279	Total Apparent Power Exported	Dword	R/W	0-999999999kWh		2
2058H-2059H	8280-8281	Total Apparent Power Exported Phase A	Dword	R/W	0-999999999kWh		2
205AH-205BH	8282-8283	Total Apparent Power Exported Phase B	Dword	R/W	0-999999999kWh		2
205CH-205DH	8284-8285	Total Apparent Power Exported Phase C	Dword	R/W	0-999999999kWh		2
205EH-205FH	8286-8287	Total Apparent Power Imported	Dword	R/W	0-999999999kWh		2
2060H-2061H	8288-8289	Total Apparent Power Imported Phase A	Dword	R/W	0-999999999kWh		2
2062H-2063H	8290-8291	Total Apparent Power Imported Phase B	Dword	R/W	0-999999999kWh		2
2064H-2065H	8292-8293	Total Apparent Power Imported Phase C	Dword	R/W	0-999999999kWh		2
2066H-2067H	8294-8295	Total Reactive Imported Q1	Dword	R/W	0-999999999kWh		2
2068H-2069H	8296-8297	Total Reactive Imported Q1 Phase A	Dword	R/W	0-999999999kWh		2
206AH-206BH	8298-8299	Total Reactive Imported Q1 Phase B	Dword	R/W	0-999999999kWh		2
206CH-206DH	8300-8301	Total Reactive Imported Q1 Phase C	Dword	R/W	0-999999999kWh		2
206EH-206FH	8302-8303	Total Reactive Imported Q2	Dword	R/W	0-999999999kWh		2
2070H-2071H	8304-8305	Total Reactive Imported Q2 Phase A	Dword	R/W	0-999999999kWh		2
2072H-2073H	8306-8307	Total Reactive Imported Q2 Phase B	Dword	R/W	0-999999999kWh		2
2074H-2075H	8308-8309	Total Reactive Imported Q2 Phase C	Dword	R/W	0-999999999kWh		2
2076H-2077H	8310-8311	Total Reactive Imported Q3	Dword	R/W	0-999999999kWh		2
2078H-2079H	8312-8313	Total Reactive Imported Q3 Phase A	Dword	R/W	0-999999999kWh		2
207AH-207BH	8314-8315	Total Reactive Imported Q3 Phase B	Dword	R/W	0-999999999kWh		2
207CH-207DH	8316-8317	Total Reactive Imported Q3 Phase C	Dword	R/W	0-999999999kWh		2
207EH-207FH	8318-8319	Total Reactive Imported Q4	Dword	R/W	0-999999999kWh		2
2080H-2081H	8320-8321	Total Reactive Imported Q4 Phase A	Dword	R/W	0-999999999kWh		2
2082H-2083H	8322-8323	Total Reactive Imported Q4 Phase B	Dword	R/W	0-999999999kWh		2
2084H-2085H	8324-8325	Total Reactive Imported Q4 Phase C	Dword	R/W	0-999999999kWh		2



Table 5-12 Clock Address

MODBUS Address		Parameter Description	Data Type	R/W	Data Range	Default	Model	Register Number
Hex	Decimal							
300H	768	Clock: Year	Word	R/W	2000-2099	2000	2~4	1
301H	769	Clock: Month	Word	R/W	1-12	1	2~4	1
302H	770	Clock: Date	Word	R/W	1-31	1	2~4	1
303H	771	Clock: Hour	Word	R/W	0-23	0	2~4	1
304H	772	Clock: Minute	Word	R/W	0-59	0	2~4	1
305H	773	Clock: Second	Word	R/W	0~6 0: Sunday 1~6 Monday-Saturday	6	2~4	1
310H-311H	784-785	Run_time	Uint32		0-999999999 (Communication value is 100 times of the real value)		2~4	2
312H-313H	786-787	Load_time	Uint32		0-999999999 (Communication value is 100 times of the real value)		2~4	2

### Daylight Saving Time Setting (03H: Read 10H: Write)

Table 5-13 Daylight saving time address table

MODBUS Address		Parameter Description	Data Type	R/W	Data Range	Default	Model	Register Number
Hex	Decimal							
<b>Daylight Saving Time Setting</b>								
350H	848	DST enable	Word	R/W	0: disable 1: enable	0	2~4	1
351H	849	DST format	Word	R/W	0: format 1 (fixed date) 1: format 2 (non fixed date)	0	2~4	1
<b>Format 1: Fixed Date</b>								
352H	850	DST Start Month	Word	R/W	1~12	1	2~4	1
353H	851	DST Start Day	Word	R/W	1~31	1	2~4	1
354H	852	DST Start Hour	Word	R/W	0~23	0	2~4	1
355H	853	DST Start Min	Word	R/W	0-59	0	2~4	1

356H	854	DST Start Adjust Time (Unit: Minute)	Word	R/W	1-120	60	2~4	1
357H	854	DST Ending Month	Word	R/W	1-12	1	2~4	1
358H	856	DST Ending Date	Word	R/W	1-31	1	2~4	1
359H	857	DST Ending Hour	Word	R/W	0-23	0	2~4	1
35AH	858	DST Ending Minute	Word	R/W	0-59	0	2~4	1
35BH	859	DST Adjust time (Unit: Minute)	Word	R/W	1-120	60	2~4	1

**Format 2: Non Fixed Date**

35CH	860	DST Start Month	Word	R/W	1~12	1	2~4	1
35DH	861	DST Start Day	Word	R/W	0~6	0	2~4	1
35EH	862	DST Start Week	Word	R/W	1~5	1	2~4	1
35FH	863	DST Start Hour	Word	R/W	0~23	0	2~4	1
360H	864	DST Start Minute	Word	R/W	0~59	0	2~4	1
361H	865	DST Start Adjust Time (Unit: Minute)	Word	R/W	1~120	60	2~4	1
362H	866	DST Ending Month	Word	R/W	1~12	1	2~4	1
363H	867	DST Ending Day	Word	R/W	0~6 0: Sunday 1~6 Monday-Saturday	0	2~4	1
364H	868	DST Ending Week	Word	R/W	1~5	1	2~4	1
365H	869	DST Ending Hour	Word	R/W	0~23	0	2~4	1
366H	870	DST Ending Minute	Word	R/W	0~59	0	2~4	1
367H	871	DST Ending Adjust time (Unit: minute)	Word	R/W	1~120	60	2~4	

## Time of Use (TOU) Energy

Table 5-14 TOU Energy Address

MODBUS Address		Parameter Description	Data Type	R/W	Range	Default	Model	Register Number
Hex	Decimal							
<b>TOU Parameter</b>								
400H	1024	Wrong Parameter Setting 1			See Appendix “Tariff Parameter Writing Information 1”		2~4	1
401H	1025	Wrong Parameter Setting 2			See Appendix “Tariff Parameter Wrong Information 1”		2~4	1
402H	1026	Time Zone Selecting	Word	R/W	1-14	1	2~4	1
403H	1027	Schedule Setting: number of schedules to configure	Word	R/W	1-8	2	2~4	1
404H	1028	Segment Setting: number of time segments per schedule	Word	R/W	1-14	2	2~4	1
405H	1029	Tariff: number of tariffs to configure	Word	R/W	1-4	4	2~4	1
406H	1030	Weekend Setting	Word	R/W	Bit0-Bit6 1: Weekdays; 0: Weekends	0	2~4	1
407H	1031	Weekend Schedule	Word	R/W	1-8	1	2~4	1
408H	1032	Number of Holidays	Word	R/W	0-30	0	2~4	1
409H	1033	TOU auto reset fixed date: day(default is 1)	Word	R/W	1-28	1	2~4	1
40AH	1034	TOU auto reset fixed date: hour (default is 0)	Word	R/W	0-23	0	2~4	1
40BH	1035	TOU Enable	Word	R/W	0: disable; 1: enable	0	2~4	1
40CH	1036	TOU Settings Number	Word	R/W	0: System Setting 1: Communication	0	2~4	1
40DH	1037	Current number of tariffs to configure	Word	R/W	1-4 Only can change when the TOU Tariff Number is set as 1, Communication	1	2~4	1
40EH	1038	TOU Settings – reset to factory default	Word	R/W	Only ‘0x0A’ Valid		2~4	1

TOU Schedule Parameters								
420H-422H	1056-1058	Time Zone 1: starting Month, Day, Schedule Table number		R/W		02-01 01	2~4	3
423H-425H	1059-1061	Time Zone 2: starting Month, day, Schedule Table number		R/W		06-01 02	2~4	3
426H-428H	1062-1064	Time Zone 3: starting Month, Day, Schedule Table number		R/W		10-01 03	2~4	3
429H-42BH	1065-1067	Time Zone 4: starting Month, Day, Schedule Table number		R/W		00-00 00	2~4	3
42CH-42EH	1068-1070	Time Zone 5: starting Month, Day, Schedule Table number		R/W		00-00 00	2~4	3
42FH-431H	1071-1073	Time Zone 6: starting Month, Day, Schedule Table number		R/W		00-00 00	2~4	3
432H-434H	1074-1076	Time Zone 7: starting Month, Day, Schedule Table number		R/W		00-00 00	2~4	3
435H-437H	1077-1079	Time Zone 8: starting Month, Day, Schedule Table number		R/W		00-00 00	2~4	3
438H-43AH	1080-1082	Time Zone 9: starting Month, Day, Schedule, Table number		R/W		00-00 00	2~4	3
43BH-43DH	1083-1085	Time Zone 10: starting Month, Day, Schedule Table number		R/W		00-00 00	2~4	3
43EH-440H	1086-1088	Time Zone 11: starting Month, Day, Schedule Table number		R/W		00-00 00	2~4	3
441H-443H	1089-1091	Time Zone 12: starting Month, Day, Schedule Table Number		R/W		00-00 00	2~4	3

444H-446H	1092-1094	Time Zone 13: starting Month, Day, Schedule Table Number		R/W		00-00 00	2~4	3
447H-449H	1095-1097	Time Zone 14: starting Month, Day, Schedule Table Number		R/W		00-00 00	2~4	3
44AH-44CH	1098-1100	Schedule Table 1, 1st segment (Hour, Minute, Tariff Number)		R/W		07:12 01	2~4	3
44DH-44FH	1101-1103	Schedule Table 1, 2nd segment (Hour, Minute, Tariff Number)		R/W		15:22 03	2~4	3
450H-452H	1104-1106	Schedule Table 1, 3rd segment (Hour, Minute, Tariff Number)		R/W		00:00 00	2~4	3
453H-455H	1107-1109	Schedule Table 1, 4th segment (Hour, Minute, Tariff Number)		R/W		00:00 00	2~4	3
456H-458H	1110-1112	Schedule Table 1, 5th segment (Hour, Minute, Tariff Number)		R/W		00:00 00	2~4	3
459H-45BH	1113-1115	Schedule Table, 6th segment (Hour, Minute, Tariff Number)		R/W		00:00 00	2~4	3
45CH-45EH	1116-1118	Schedule Table 1, 7th segment (Hour, Minute, Tariff Number)		R/W		00:00 00	2~4	3
45FH- 461H	1119-1121	Schedule Table 1, 8th segment (Hour, Minute, Tariff Number)		R/W		00:00 00	2~4	3
462H- 464H	1122-1124	Schedule 1, 9th segment (Hour, Minute, Tariff Number)		R/W		00:00 00	2~4	3
465H- 467H	1125-1127	Schedule Table 1, 10th segment (Hour, Minute, Tariff Number)		R/W		00:00 00	2~4	3
468H- 46AH	1128-1130	Schedule Table 1, 11th segment (Hour, Minute, Tariff Number)		R/W		00:00 00	2~4	3

46BH- 46DH	1131-1133	Schedule Table 1, 12th segment (Hour, Minute, Tariff Number)		R/W		00:00 00	2~4	3
46EH- 470H	1134-1136	Schedule Table 1, 13th Segment (Hour, Minute, Tariff Number)		R/W		00:00 00	2~4	3
471H- 473H	1137-1139	Schedule Table 1, 14th segment (Hour, Minute, Tariff Number)		R/W		00:00 00	2~4	3
474H-49DH	1140-1181	Schedule Table 2, 1st -14th segment (Hour, Minute, Tariff Number)		R/W		00:00 00	2~4	42
49EH- 4C7H	1182-1223	Schedule Table 3, 1st -14th segment (Hour, Minute, Tariff Number)		R/W		00:00 00	2~4	42
4C8H- 4F1H	1224-1265	Schedule Table 4, 1st - 14th segment (Hour, Minute, Tariff Number)		R/W		00:00 00	2~4	42
4F2H- 51BH	1308-1349	Schedule Table 6, 1st - 14th segment (Hour, Minute, Tariff Number)		R/W		00:00 00	2~4	42
546H- 56FH	1350-1391	Schedule Table 7, 1st - 14th segment (Hour, Minute, Tariff Number)		R/W		00:00 00	2~4	42
570H- 599H	1392-1433	Schedule Table 8, 1st - 14th segment (Hour, Minute, Tariff Number)		R/W		00:00 00	2~4	42
59AH- 59CH	1434-1436	The 1st special day (Month, Day, Schedule Table Number)		R/W		03-12 01	2~4	3

59DH- 59FH	1437-1439	The 2nd special day (Month, Day, Schedule Table Number)		R/W		05-02 03	2~4	3
5A0H- 5A2H	1440-1442	The 3rd special day (Month, Day, Schedule Table number)		R/W		00-00 00	2~4	3
5A3H- 5A5H	1443-1445	The 4th special day (Month, Day, Schedule Table Number)		R/W		00-00 00	2~4	3
5A6H- 5A8H	1446-1448	The 5th special day (Month, Day, Schedule Table Number)		R/W		00-00 00	2~4	3
5A9H- 5ABH	1449-1451	The 6th special day (Month, Day, Schedule Table Number)		R/W		00-00 00	2~4	3
5ACH- 5AEH	1452-1454	The 7th special day (Month, Day, Schedule Table Number)		R/W		00-00 00	2~4	3
5AFH-5B1H	1455-1457	The 8th special day (Month, Day, Schedule Table Number)		R/W		00-00 00	2~4	3
5B2H- 5B4H	1458-1460	The 9th special day (Month, Day, Schedule Table Number)		R/W		00-00 00	2~4	3
5B5H- 5B7H	1461-1463	The 10th special day (Month, Day, Schedule Table Number)		R/W		00-00 00	2~4	3
5B8H- 5F3H	1464-1523	The 11th ~30th special day (Month, Day, Schedule Table Number)		R/W			2~4	3

Table 5-15 Last/Previous Month Demand Max

MODBUS Address		Parameter Description	Data Type	Property	Range	Model	Register Number
Hex	Decimal						
1800H-1801H	6144-6145	Total Imported Active Power Demand Peak	Float	R	Xx.xxxx kw	2~4	2
1802H-1804H	6146-6147	Total Imported Active Power Demand Peak Time	Dword	R	YY/MM/DD/hh/mm/ss (Second always is 0)	2~4	3
1805H-1806H	6148-6149	Imported Active Power Demand 1 Peak	Float	R	Xx.xxxx kw	2~4	2
1807H-1809H	6150-6151	Imported Active Power Demand 1 Peak Time	Dword	R	YY/MM/DD/hh/mm/ss (Second always is 0)	2~4	3
180AH-180BH	6152-6153	Imported Active Power Demand 2 Peak	Float	R	Xx.xxxx kw	2~4	2
180CH-180EH	6154-6155	Imported Active Power Demand 2 Peak Time	Dword	R	YY/MM/DD/hh/mm/ss (Second always is 0)	2~4	3
180FH-1810H	6156-6157	Imported Active Power Demand 3 Peak	Float	R	Xx.xxxx kw	2~4	2
1811H-1813H	6158-6159	Imported Active Power Demand 3 Peak Time	Dword	R	YY/MM/DD/hh/mm/ss (Second always is 0)	2~4	3
1814H-1815H	6160-6161	Imported Active Power Demand 4 Peak	Fl1802H-1804Hoat	R	Xx.xxxx kw	2~4	2
1816H-1818H	6162-6163	Imported Active Power Demand 4 Peak Time	Dword	R	YY/MM/DD/hh/mm/ss (Second always is 0)	2~4	3
1819H-181AH	6164-6165	Total Exported Active Power Demand Peak	Float	R	Xx.xxxx kw	2~4	2
181BH-181CH	6166-6167	Total Exported Active Power Demand Peak Time	Dword	R	YY/MM/DD/hh/mm/ss (Second always is 0)	2~4	3
181DH-181EH	6168-6169	Exported Active Power Demand 1 Peak	Float	R	Xx.xxxx kw	2~4	2
181FH-1821H	6170-6171	Exported Active Power Demand 1 Peak Time	Dword	R	YY/MM/DD/hh/mm/ss (Second always is 0)	2~4	3
1822H-1823H	6172-6173	Exported Active Power Demand 2 Peak	Float	R	Xx.xxxx kw	2~4	2
1824H-1826H	6174-6175	Exported Active Power Demand 2 Peak Time	Dword	R	YY/MM/DD/hh/mm/ss (Second always is 0)	2~4	3



1827H-1828H	6176-6177	Exported Active Power Demand 3 Peak	Float	R	Xx.xxxx kw	2~4	2
1829H-182BH	6178-6179	Exported Active Power Demand 3 Peak Time	Dword	R	YY/MM/DD/hh/mm/ss (Second always is 0)	2~4	3
182CH-182DH	6180-6181	Exported Active Power Demand 4 Peak	Float	R	Xx.xxxx kw	2~4	2
182EH-1830H	6182-6183	Exported Active Power Demand 4 Peak Time	Dword	R	YY/MM/DD/hh/mm/ss (Second always is 0)	2~4	3
1831H-1832H	6184-6185	Total Imported Reactive Power Demand Peak	Float	R	Xx.xxxx kw	2~4	2
1833H-1835H	6186-6187	Total Imported Reactive Power Demand Peak Time	Dword	R	YY/MM/DD/hh/mm/ss (Second always is 0)	2~4	3
1836H-1837H	6188-6189	Imported Reactive Power Demand 1 Peak	Float	R	Xx.xxxx kw	2~4	2
1838H-183AH	6190-6191	Imported Reactive Power Demand 1 Peak Time	Dword	R	YY/MM/DD/hh/mm/ss (Second always is 0)	2~4	3
183BH-183CH	6192-6193	Imported Reactive Power Demand 2 Peak	Float	R	Xx.xxxx kw	2~4	2
183DH-183FH	6194-6195	Imported Reactive Power Demand 2 Peak Time	Dword	R	YY/MM/DD/hh/mm/ss (Second always is 0)	2~4	3
1840H-1841H	6196-6197	Imported Reactive Power Demand 3 Peak	Float	R	Xx.xxxx kw	2~4	2
1842H-1844H	6198-6199	Imported Reactive Power Demand 3 Peak Time	Dword	R	YY/MM/DD/hh/mm/ss (Second always is 0)	2~4	3
1845H-1846H	6200-6201	Imported Reactive Power Demand 4 Peak	Float	R	Xx.xxxx kw	2~4	2
1847H-1849H	6202-6203	Imported Reactive Power Demand 4 Peak Time	Dword	R	YY/MM/DD/hh/mm/ss (Second always is 0)	2~4	3
184AH-184BH	6204-6205	Total Exported Reactive Power Demand Peak	Float	R	Xx.xxxx kw	2~4	2
184CH-184EH	6206-6207	Total Exported Reactive Power Demand Peak Time	Dword	R	YY/MM/DD/hh/mm/ss (Second always is 0)	2~4	3
184FH-1850H	6208-6209	Exported Reactive Power Demand 1 Peak	Float	R	Xx.xxxx kw	2~4	2

1851H-1853H	6210-6211	Exported Reactive Power Demand 1 Peak Time	Dword	R	YY/MM/DD/hh/mm/ss (Second always is 0)	2~4	3
1854H-1855H	6212-6213	Exported Reactive Power Demand 2 Peak	Float	R	Xx.xxxx kw	2~4	2
1856H-1858H	6214-6215	Exported Reactive Power Demand 2 Peak Time	Dword	R	YY/MM/DD/hh/mm/ss (Second always is 0)	2~4	3
1859H-185AH	6216-6217	Exported Reactive Power Demand 3 Peak	Float	R	Xx.xxxx kw	2~4	2
185BH-185DH	6218-6219	Exported Reactive Power Demand 3 Peak Time	Dword	R	YY/MM/DD/hh/mm/ss (Second always is 0)	2~4	3
185FH-1860H	6220-6221	Exported Reactive Power Demand 4 Peak	Float	R	Xx.xxxx kw	2~4	2
1861H-1863H	6222-6223	Exported Reactive Power Demand 4 Peak H Time	Dword	R	YY/MM/DD/hh/mm/ss (Second always is 0)	2~4	3
1864H-1865H	6224-6225	Total Apparent Power Demand Peak	Float	R	Xx.xxxx kw	2~4	2
1866H-1868H	6226-6227	Total Apparent Power Demand Peak Time	Dword	R	YY/MM/DD/hh/mm/ss (Second always is 0)	2~4	3
1869H-186AH	6228-6229	Phase A Current Demand Peak		R	Xx.xxxx A	2~4	2
186BH-186DH	6230-6231	Phase A Current Demand Peak Time	Dword	R	YY/MM/DD/hh/mm/ss (Second always is 0)	2~4	3
186EH-186FH	6232-6233	Phase B Current Demand Peak	Float	R	Xx.xxxx A	2~4	2
1870H-1872H	6234-6235	Phase B Current Demand Peak Time	Dword	R	YY/MM/DD/hh/mm/ss (Second always is 0)	2~4	3
1873H-1874H	6236-6237	Phase C Current Demand Peak		R	Xx.xxxx A	2~4	2
1875H-1877H	6238-6239	Phase C Current Demand Peak Time	Dword	R	YY/MM/DD/hh/mm/ss (Second always is 0)	2~4	3

Table 5-16 TOU Week Alternatives

MODBUS Address		Parameter Description	Data Type	Access Property	Range	Default	Model	Register Number
Hex	Decimal							
7F00H	32512	Enable Weekend Alternative	word	R/W	1: Enable; 0: Disable	0	2~4	1
7F01H	32513	Season 1:Sign of the Weekend	word	R/W	Bit0: Sunday, 1 Enable, 0 Disable; Bit1: Monday, 1 Enable, 0 Disable; ..... Bit6: Saturday, 1 Enable, 0 Disable;	0	2~4	1
7F02H	32514	Season 1:The schedule Table number of Sunday	word	R/W		0	2~4	1
7F03H	32515	Season 1:The schedule Table number of Monday	word	R/W		0	2~4	1
7F04H	32516	Season 1:The schedule Table number of Tuesday	word	R/W		0	2~4	1
7F05H	32517	Season 1:The schedule Table number of Wednesday	word	R/W			2~4	1
7F06H	32518	Season 1:The schedule Table number of Thursday	word	R/W			2~4	
7F07H	32519	Season 1:The schedule Table number of Friday	word	R/W			2~4	
7F08H	32520	Season 1:The schedule Table number of Saturday	word	R/W			2~4	
7F09H - 7F10H	32521-32522	Season 2 of Week-end Alternative	word	R/W			2~4	
7F11H - 7F18H	32523 -32536	Season 3 of Week-end Alternative	word	R/W			2~4	
7F19H - 7F20H	32537-32538	Season 4 of Week-end Alternative	word	R/W			2~4	
7F21H - 7F28H	32539 -32552	Season 5 of Week-end Alternative	word	R/W			2~4	

7F29H -7F30H	32553 -32554	Season 6 of Week- end Alternative	word	R/W			2~4	
7F31H -7F38H	32555 - 32568	Season 7 of Week- end Alternative	word	R/W			2~4	
7F39H -7F40H	32569 -32570	Season 8 of Week- end Alternative	word	R/W			2~4	
7F41H -7F48H	32571 - 32584	Season 9 of Week- end Alternative	word	R/W			2~4	
7F49H -7F50H	32585 - 32586	Season 10 of Week- end Alternative	word	R/W			2~4	
7F51H -7F58H	32587 - 32600	Season 11 of Week- end Alternative	word	R/W			2~4	
7F59H -7F60H	32601-32602	Season 12 of Week- end Alternative	word	R/W			2~4	
7F61H -7F68H	32603 - 32616	Season 13 of Week- end Alternative	word	R/W			2~4	
7F69H -7F70H	32617 - 32618	Season 14 of Week- end Alternative	word	R/W			2~4	

**Rate parameter error information word 1 (basic parameter)**

Table 5-17 Rate parameter error information word 1

Bit7	Bit6	Bit5	Bit4	Bit3	Bit2	Bit1	Bit0
1	1	1	1	1	1	1	1
Time segment table 8 error	Time segment table 7 error	Time segment table 6 error	Time segment table 5 error	Time segment table 4 error	Time segment table 3 error	Time segment table 2 error	Time segment table 1 error

**Rate parameter error information word 2 (time segment table parameter)**

Table 5-18 Rate parameter error information word 2

Bit7	Bit6	Bit5	Bit4	Bit3	Bit2	Bit1	Bit0
1	1	1	1	1	1	1	1
Time segment table 8 error	Time segment table 7 error	Time segment table 6 error	Time segment table 5 error	Time segment table 4 error	Time segment table 3 error	Time segment table 2 error	Time segment table 1 error

## Alarm Parameter Setting (Function Code: 03H to Read; 10H to Write)

Table 5-19 Alarm Parameters

MODBUS Address		Parameter Description	Data Type	R/W	Range	Default	Model	Register Number
Hex	Decimal							
700H	1792	Alarm Switch	Word	R/W	1: Enable; 0: Disable	0	2~4	1
701H	1793	Alarm Channel	Word	R/W	Bit0~Bit11: Alarm Channel 0-11 1: Enable; 0: Disable	0	2~4	1
702	1794	Alarm Channel Output	Word	R/W	Bit0~ Bit11: Alarm Channel 0-11 1: Enable; 0: Disable	0	2~4	1
703	1795	Alarm Output Mode	Word	R/W	0: level; 1: pulse	0	2~4	1
704H	1796	Pulse Output Time	Word	R/W	50~3000ms (valid with Pulse Output Mode)	1000	2~4	1
<b>Alarm Parameter Setting for the 1st group</b>								
705H	1797	Parameter Number	Word	R/W	0~28 (Please see appendix "Alarm Parameter comparison table")	0	2~4	1
706H	1798	Comparing Method	Word	R/W	0: larger; 1: equal; 2: less	0	2~4	1
707H	1799	Setpoint Value	Word	R/W	0: larger; 1: equal; 2: less	0	2~4	1
708H	1800	Delay Time	Word	R/W	0~3000 (x10ms)	0	2~4	1
<b>Alarm Parameter Setting for the 2nd 12th group</b>								
709H-703BH	1801-1851	The same as above	Word	R/W			2~4	44

Table 5-20 SunSpec System Information Address

MODBUS Address		Parameter Description	Data Type	R/W	Range	Default	Model	Register Number
Hex	Decimal							
1000H -1001H	4096 -4097	SunSpec_ID	Uint16	R	0x53756e53	1	2~4	2
1002H	4098	ID	Uint16	R	1	1	2~4	1
1003H	4099	Length	Uint16	R	65	6	2~4	1
1004H -1013H	4100-4115	Manufacturer	String	R	Well known value registered with SunSpec for compliance	Accuenergy	2~4	16
1014H -1023H	4116-4131	Model	String	R	Manufacturer specific value (32 characters)	AcuRev 1310	2~4	16
1024H -102BH	4132-4139	Options	String	R	Manufacturer specific value (16 characters)	AcuRev 1310	2~4	8
102CH -1033H	4140-4147	Version	String	R	Manufacturer specific value (32 characters)	H: 1.10 S;1.01	2~4	8
1034H -1043H	4148-4163	Serial Number	String	R	Manufacturer specific value (32 characters)		2~4	16
1044H	4164	Device Address	Uint16	R/W	Modbus device address		2~4	1
1045H	4165	ID	Uint16	R	Meter (Single Phase) single phase (AN or AB) meter --201 Split single phase (ABN) meter --202 wye-connect three phase (ABCN) meter --203 Delta-connect three phase (ABC) meter --204		2~4	1
1046H	4166	Length	Uint16	R	105		2~4	1
1047H	4167	Amps (total): SunSpec; Total Current AcuRev 1310	Int16	R	0-9999 A		2~4	1
1048H	4168	Amps Phase A: SunSpec; Phase A Current AcuRev 1310	Int16	R	0-9999 A		2~4	1
1049H	4169	Amps Phase B: SunSpec; Phase B Current: AcuRev 1310	Int16	R	0-9999 A		2~4	1
104AH	4170	Amps Phase C: SunSpec; Phase C Current AcuRev 1310	Int16	R	0-9999 A		2~4	1
104BH	4171	Current scale factor: SunSpec; CT Ratio: AcuRev 1310	Sunssf	R	-3~+5 (used as exponent of a power of 10)		2~4	1

MODBUS Address		Parameter Description	Data Type	R/W	Range	Default	Model	Register Number
Hex	Decimal							
104CH	4172	Voltage LN (average): SunSpec; CT Ratio: AcuRev 1310	Int16	R	0-9999 V		2~4	1
104DH	4173	Phase Voltage AN: SunSpec; Phase Average Voltage: AcuRev 1310	Int16	R	0-9999 V		2~4	1
104EH	4174	Phase Voltage BN: SunSpec; Phase B Voltage: AcuRev 1310	Int16	R	0-9999 V		2~4	1
104FH	4175	Phase Voltage CN: SunSpec; Phase C Voltage: AcuRev 1310	Int16	R	0-9999 V		2~4	1
1050H	4176	Voltage LL (average): SunSpec; Line Average Voltage: AcuRev 1310	Int16	R	0-9999 V		2~4	1
1051H	4177	Phase Voltage AB: SunSpec; Line AB Voltage: AcuRev1310	Int16	R	0-9999 V		2~4	1
1052H	4178	Phase Voltage BC: SunSpec; Line BC Voltage AcuRev 1310	Int16	R	0-9999 V		2~4	1
1053H	4179	Phase Voltage CA: SunSpec; Line CA Voltage: AcuRev 1310	Int16	R	0-9999 V		2~4	1
1054H	4180	Voltage scale factor: SunSpec	Sunssf	R	-2~2		2~4	1
1055H	4181	Frequency	Int16	R	45Hz-65Hz		2~4	1
1056H	4182	Frequency scale factor	Sunssf	R	-2		2~4	1
1057H	4183	Total Real Power SunSpec; Total Active Power: AcuRev 1310	Int16	R	0-9999 W		2~4	1
1058H	4184	Watts Phase A: SunSpec; Total Active Power: AcuRev 1310	Int16	R	0-9999 W		2~4	1
1059H	4185	Watts Phase A: SunSpec; Phase A Active Power: AcuRev 1310	Int16	R	0-9999 W		2~4	1

# AcuRev 1310 DIN-Rail Power Meter

MODBUS Address		Parameter Description	Data Type	R/W	Range	Default	Model	Register Number
Hex	Decimal							
105AH	4186	Watts Phase C: SunSpec; Phase C Active Power: AcuRev 1310	Int16	R	0-9999 W		2~4	1
105BH	4187	Real Power scale factor: SunSpec;	Sunssf	R	0~4		2~4	1
105CH	4188	AC Apparent Power VA: SunSpec; Total Apparent Power: AcuRev 1310	Int16	R	0-9999 VA		2~4	1
105DH	4189	VA Phase A: SunSpec; Phase A Apparent Power: AcuRev 1310	Int16	R	0-9999 VA		2~4	1
105EH	4190	VA Phase B: SunSpec; Phase B Apparent Power: AcuRev 1310	Int16	R	0-9999 VA		2~4	1
105FH	4191	VA Phase C: SunSpec; Phase C Apparent Power: AcuRev 1310	Int16	R	0-9999 VA		2~4	1
1060H	4192	Apparent Power scale factor: SunSpec;	Sunssf	R	0~4		2~4	1
1061H	4193	Reactive Power VAR: SunSpec; Total Reactive Power: AcuRev 1310	Int16	R	0-9999 VAR		2~4	1
1062H	4194	VAR Phase A: SunSpec; Phase A Reactive Power: AcuRev 1310	Int16	R	0-9999 VAR		2~4	1
1063H	4195	VAR Phase B: SunSpec; Phase B Reactive Power: AcuRev 1310	Int16	R	0-9999 VAR		2~4	1
1064H	4196	VAR Phase C: SunSpec; Phase C Reactive Power: AcuRev 1310	Int16	R	0-9999 VAR		2~4	1



MODBUS Address		Parameter Description	Data Type	R/W	Range	Default	Model	Register Number
Hex	Decimal							
1065H	4197	Reactive Power scale factor	Sunssf	R	0~4		2~4	1
1066H	4198	Power Factor	Int16	R	-1000 ~ 1000		2~4	1
1067H	4199	PF Phase A	Int16	R	-1000 ~ 1000		2~4	1
1068H	4200	PF Phase B	Int16	R	-1000 ~ 1000		2~4	1
1069H	4201	PF Phase C	Int16	R	-1000 ~ 1000		2~4	1
106AH	4202	Power Factor scale factor	Sunssf	R	-3		2~4	1
106BH -106CH	4203-4204	Total Real Energy Exported: Sun-Spec Total Active Energy Exported: AcuRev 1310	Acc32	R/W	0-999999999 kWh		2~4	2
106DH -106EH	4205-4206	Total Watt-hours Exported in phase A: Sun-Spec; Total Active Energy Exported in Phase A: AcuRev 1310	Acc32	R/W	0-999999999 kWh		2~4	2
106FH -1070H	4207-4208	Total Watt-hours Exported in phase B: Sun-Spec; Total Active Energy Exported in Phase B: AcuRev 1300	Acc32	R/W	0-999999999 kWh		2~4	2
1071H -1072H	4209-4210	Total Watt-hours Exported in Phase C: Sun-Spec; Total Active Energy Exported in Phase C: AcuRev 1310	Acc32	R/W	0-999999999 kWh		2~4	2
1073H -1074H	4211-4212	Total Real Energy Imported: Sun-Spec; Total Active Energy Imported: AcuRev 1310	Acc32	R/W	0-999999999 kWh		2~4	2
1075H -1076H	4213-4214	Total Watt-hours Imported Phase A: SunSpec; Total Active Energy Imported in Phase A: AcuRev 1310	Acc32	R/W	0-999999999 kWh		2~4	2

# AcuRev 1310 DIN-Rail Power Meter

MODBUS Address		Parameter Description	Data Type	R/W	Range	Default	Model	Register Number
Hex	Decimal							
1077H -1078H	4215-4216	Total Watt-hours Imported Phase B: SunSpec; Total Active Energy Imported in Phase B: AcuRev 1310	Acc32	R/W	0-999999999 kWh		2~4	2
1079H -107AH	4217-4218	Total Watt-hours Imported Phase C: SunSpec; Total Active Energy Imported in Phase C: AcuRev 1310	Acc32	R/W	0-999999999 kWh		2~4	2
107B	4219	TotWh_SF: SunSpec; CT ratio X PT ratio: AcuRev 1310	Sunssf	R	-3 ~ 0		2~4	1
107CH -107DH	4220-4221	Total VA-hours Exported: SunSpec; Total Apparent Power Exported: AcuRev 1310	Acc32	R/W	0-999999999 kVAh		3~4	2
107EH -17FH	4222-4223	Total VA-hours Exported Phase A: SunSpec; Total Apparent Power Exported in Phase A: AcuRev 1310	Acc32	R/W	0-999999999 kVAh		3~4	2
1080H -1081H	4224-4225	Total VA-hours Exported Phase B: SunSpec; Total Apparent Power Exported in Phase A: AcuRev 1310	Acc32	R/W	0-999999999 kVAh		3~4	2
1082H -1083H	4226-4227	Total VA-hours Exported phase C: SunSpec; Total Apparent Power Exported in Phase C: AcuRev 1310	Acc32	R/W	0-999999999 kVAh		3~4	2
1084H -1085H	4228-4229	Total VA-hours Imported: SunSpec; Total Apparent Power Imported: AcuRev 1310	Acc32	R/W	0-999999999 kVAh		2~4	2

MODBUS Address		Parameter Description	Data Type	R/W	Range	Default	Model	Register Number
Hex	Decimal							
1086H -1087H	4230-4231	Total VA-hours Imported phase A: SunSpec; Total Apparent Power Imported in Phase A: AcuRev 1310	Acc32	R/W	0-999999999 kVAh		2~4	2
1088H -1089H	4232-4233	Total VA-hours Imported Phase B: SunSpec; Total Apparent Power Imported in Phase B: AcuRev 1310	Acc32	R/W	0-999999999 kVAh		2~4	2
108AH -108BH	4234-4235	Total VA-hours Imported Phase C: SunSpec; Total Apparent Power Imported in Phase C: AcuRev 1310	Acc32	R/W	0-999999999 kVAh		2~4	2
108CH	4236	Total VAh_SF: SunSpec; CT ratio X PT ratio: AcuRev 1310	Sunssf	R	-3 ~ 0		2~4	1
108DH -108EH	4237-4238	Total VAR-hours Imported Q1:SunSpec;	Acc32	R/W	0-999999999 kvarh		2~4	2
108FH -1090H	4239-4240	Total VAR-hours Imported Q1 Phase 1A	Acc32	R/W	0-999999999 kvarh		2~4	2
1091H -1092H	4241-4242	Total VAR-hours Imported Q1 Phase B	Acc32	R/W	0-999999999 kvarh		2~4	2
1093H -1094H	4243-4244	Total VAR-hors Imported Q1 Phase C	Acc32	R/W	0-999999999 kvarh		2~4	2
1095H -1096H	4245-4246	Total VAR-hours Imported Q2 Phase A	Acc32	R/W	0-99k9999999 kvarh		2~4	2
1097H -1098H	4247-4248	Total VAR-hours Imported Q2 Phase A	Acc32	R/W	0-999999999 kvarh		2~4	2
1099H -109AH	4249-4250	Total VAR-hours Imported Q2 Phase B	Acc32	R/W	0-999999999 kvarh		2~4	2
109BH -109CH	4251-4252	Total VAR-hours Imported Q2 Phase C	Acc32	R/W	0-999999999 kvarh		2~4	2

# AcuRev 1310 DIN-Rail Power Meter

MODBUS Address		Parameter Description	Data Type	R/W	Range	Default	Model	Register Number
Hex	Decimal							
109DH -109EH	4253-4254	Total VAR-hours Exported Q3	Acc32	R/W	0-999999999 kvarh		2~4	2
109FH -10AH	4255-4256	Total VAR-hours Exported Q3 Phase A	Acc32	R/W	0-999999999 kvarh		2~4	2
10A1H -10A2H	4257-4258	Total VAR-hours Exported Q3 Phase B	Acc32	R/W	0-999999999 kvarh		2~4	2
10A3H -10A4H	4259-4260	Total VAR-hours Exported Q3 Phase C	Acc32	R/W	0-999999999 kvarh		2~4	2
10A5H -10A6H	4261-4262	Total VAR-hours Exported Q4	Acc32	R/W	0-999999999 kvarh		2~4	2
10A7H -10A8H	4263-4264	Total VAR-hours Exported Q4 Phase A	Acc32	R/W	0-999999999 kvarh		2~4	2
10A9H -10AAH	4265-4266	Total VAR-hours Exported Q4 Phase B	Acc32	R/W	0-999999999 kvarh		2~4	2
10ABH -10ACH	4267-4268	Total VAR-hours Exported Q4 Phase C	Acc32	R/W	0-999999999 kvarh		2~4	2
10ADH	4269	Total VARh_SF: SunSpec; CT ratio X PT ratio: AcuRev 1310	Sussf	R	All the energy use the same SF		2~4	1
10AEH -10AFH	4270-4271	Meter Evenet-Flags	Bitfield32	R	0	0	2~4	2
10B0H	4272	SunSpec_end_ID: SunSpec;	UInt16		0xFFFF		2~4	1
10B1H	4273	SunSpec_end_length: SunSpec	UInt16		0x0000		2~4	1

Table 5-21 Current Maximum demand and time of occurrence address

MODBUS Address		Parameter Description	Data Type	R/W	Range	Default	Model	Register Number
Hex	Decimal							
<b>Current maximum demand and time of occurrence data</b>								
1600H-1601H 1602H-1604H	5632-5633 5634-5636	Input active power total max demand and occur time	Float Dword	R	xx.xxxx kW YYMMD-Dhhmss (Second always be 0)		3,4	2 3
1605H-1606H 1607H-1609H	5637-5638 5639-5641	Input active power max demand 1 and occur time	Float Dword	R	xx.xxxx kW YYMMD-Dhhmss		3,4	2 3
160AH-160BH 160CH-160EH	5642-5643 5644-5646	Input active power max demand 2 and occur time	Float Dword	R	xx.xxxx kW YYMMD-Dhhmss		3,4	2 3
160FH-1600H 1611H-1613H	5647-5648 5649-5651	Input active power max demand 3 and occur time	Float Dword	R	xx.xxxx kW YYMMD-Dhhmss		3,4	2 3
1614H-1615H 1616H-1618H	5652-5653 5654-5656	Input active power max demand 4 and occur time	Float Dword	R	xx.xxxx kW YYMMD-Dhhmss		3,4	2 3
1619H-161AH 161BH-161DH	5657-5658 5659-5661	Output active powers total max demand and occur time	Float Dword	R	xx.xxxx kW YYMMD-Dhhmss		3,4	2 3
161EH-161FH 1620H-1622H	5662-5663 5664-5666	Output active power max demand 1 and occur time	Float DWORD	R	xx.xxxx kW YYMMD-Dhhmss		3,4	2 3
1623H-1624H 1625H-1627H	5667-5668 5669-5671	Output active power max demand 2 and occur time	Float Dword	R	xx.xxxx kW YYMDDhhmss		3,4	2 3
1628H-1629H 162AH-162C	5672-5673 5674-5676	Output active power max demand 3 and occur time	Float Dword	R	xx.xxxx kW YYMMD-Dhhmss		3,4	2 3
162DH-162EH 162FH-1631H	5677-5678 5679-5681	Output active power max demand 4 and occur time	Float Dword	R	xx.xxxx kW YYMMD-Dhhmss		3,4	2 3
1632H-1633H 1634H-1636H	5682-5683 5684-5686	Input reactive power max demand 1 and occur time	Float Dword	R	xx.xxxx kvar YYM-MDDhhmss		3,4	2 3
1637H-1638H 1639H-163BH	5687-5688 5689-5691	Input reactive power max demand 1 and occur time	Float Dword	R	xx.xxxx kvar YYM-MDDhhmss		3,4	2 3
163CH-163DH 163EH-1640H	5692-5693 5694-5696	Input reactive power max demand 2 and occur time	Float Dword	R	xx.xxxx kvar YYM-MDDhhmss		3,4	2 3
1641H-1642H 1643H-1645H	5697-5698 5699-5701	Input reactive power max demand 3 and occur time	Float Dword	R	xx.xxxx kvar YYMDDhhmss		3,4	2 3
1646H-1647H 1648H-164AH	5702-5703 5704-5706	Input reactive power max demand 4 and occur time	Float Dword	R	xx.xxxx kvar YYMDDhhmss		3,4	2 3

MODBUS Address		Parameter Description	Data Type	R/W	Range	Default	Model	Register Number
Hex	Decimal							
164BH-164CH 164DH-164FH	5707-5708 5709-5711	Output reactive powers total max demand and occur	Float Dword	R	xx.xxxx kvar YYM-MDDhhmmss		3,4	2 3
1650H-1651H 1652H-1654H	5712-5713 5714-5715	Output reactive power max demand 1 and occur time	Float Dword	R	xx.xxxx kvar YYM-MDDhhmmss		3,4	2 3
1655H-1656H 1657H-1659H	5718-5720 5716-5717	Output reactive power max demand 2 and occur time	Float Dword	R	xx.xxxx kvar YMMDDhhmmss		3,4	2 3
165AH-165BH 165CH-165EH	5721-5722 5723-5725	Output reactive power max demand 3 and occur time	Float Dword	R	xx.xxxx kvar YMMDDhhmmss		3,4	2 3
165FH-1660H 1661H-1663H	5726-5727 5728-5730	Output reactive power max demand 4 and occur time	Float Dword	R	xx.xxxx kvar YYM-MDDhhmmss		3,4	2 3
1664H-1665H 1666H-1668H	5731-5732 5733-5735	Apparent power total max demand and occur time	Float Dword	R	xx.xxxx kVA YYMMD-Dhhmmss		3,4	2 3
1669H-166AH 166BH-166DH	5736-5737 5738-5740	Phase A current max demand and occur time	Float Dword	R	xx.xxxx A YYMMD-Dhhmmss		3,4	2 3
166EH-166FH 1670H-1672H	5741-5742 5743-5744	Phase B current max demand and occur time	Float Dword	R	xx.xxxx A YYMMD-Dhhmmss		3,4	2 3
1673H-1674H 1675H-1677H	5745-5746 5747-5748	Phase C current max demand and occur time	Float Dword	R	xx.xxxx A YYMMD-Dhhmmss		3,4	2 3
1678H-1690H	5749-5776	Reserved						

## Event logging (03H: read)

Table 5-22 Event Logging

MODBUS Address		Parameter Description	Data Type	R/W	Range	Default	Model	Register Number
Hex	Decimal							
1D00H-1D01H	7424-7425	Total times of Event Reset (Total Reset and each parameter reset)	Word	R	0~ 0xFFFFFFFF		2~4	2
<b>Last Event Reset Record</b>								
1D02H-1D04H	7426-7428	Event Reset Happening Time	Word	R	YY/MM/DD/hh/mm/ss		2~4	3
1D05H	7429	Event Reset Marking Code	Word	R	1: Reset Event Record; 2: Reset Demand Record; 3: Reset Meter Opening Record; 4: Reset Alarm; 5: Reset Meter Operation Time; 6: Reset Time of Meter Operation with Load;		2~4	1
<b>Last 2<sup>nd</sup> Event Reset Record</b>								
1D06H-1D09H	7430-7433						2~4	8
<b>Last 3<sup>rd</sup> Event Reset Record</b>								
1D0AH-1D0DH	7434-7437							

## Programming Record

Table 5-23 Programming record address

Modbus Address		Parameter Description	Data Type	R/W	Range	Default	Model	Register Number
Hex	Decimal							
1A00H-1A01H	6656-6657	Total programming time	Dword	R	0-999999		2-4	2
<b>Last Event Reset Record</b>								
1A02H-1A04H	6658-6660	Occur time	Word	R	YYMMDDhmmss		2-4	3
<b>Last 2<sup>nd</sup> Event Reset Record</b>								
1A06H-1A0DH	6662-6669						2-4	8
<p>Note*:            System Event Marking:            01: Meter Address Change 02: RS485 Parameter Change(including Baud Rate and Parity bit setting)            03: Energy Pulse Setting 04: Demand Parameter Setting(calculation method, demand period, slipping time) 05: Reactive power calculation method 06:VAR/PF Convention 07: Date and Time Setting            08: Measure side change 09: Wiring Mode 10: CT or PT change 11: Pulse Constant and Pulse Width            12: Decimal Digits 13: RO Output Mode 14: Alarm Setting Parameter            100: Energy Value Base 101: TOU Parameter Setting            102: Daylight Saving Time 103: Trend Record            104: Alarm set parameters change</p>								

## Demand Clearance Event

Table 5-24 Demand Clearance Address

Modbus Address		Parameter Description	Data Type	R/W	Range	Default	Model	Register Number
Hex	Decimal							
1B00H-1B01H	6912-6913	Total Times of Demand Reset	Word	R	0~0xFFFFFFFF		2-4	2
<b>Last time open cover record</b>								
1B02H-1B04H	6914-6916	Occur time	Word	R	YYMMDDhmmss		2-4	3
<b>Last 2<sup>nd</sup> - 3<sup>rd</sup> time</b>								
1B05H-1B0AH	6917-6916						2-4	6

## Open Cover Record

Table 5-25 Open Cover Record Address

Modbus Address		Parameter Description	Data Type	R/W	Range	Default	Model	Register Number
Hex	Decimal							
1C00H-1C01H	7168-7169	Total open cover time	Word	R	0-999999		2-4	2
<b>Last time open cover record</b>								
1C02H-1C04H	7170-7172	Occur time	Word	R	Y Y M M D - Dhhmmss		2-4	3
1C05H-1C07H	7173-7175	End time	Word	R			2-4	3
<b>Last 2<sup>nd</sup> - 3<sup>rd</sup> time</b>								
1C08H-1C13H	7176-7187						2-4	12

## Event Clearance

Table 5-26 Event Clearance Address

Modbus Address		Parameter Description	Data Type	R/W	Range	Default	Model	Register Number
Hex	Decimal							
1D00H-1D01H	7424-7425	Total event clearance time	Word	R			2-4	2
<b>Last time open cover record</b>								
1D02H-1D04H	7426-7428	Occur Time	Word	R	YYMMDDhhmmss		2-4	3
1D05H	7429	Event clearance data flag	Word	R	1: clear the programming records 2: clear demand records 3: clear open cover records		2-4	1
<b>Last 2<sup>nd</sup> - 3<sup>rd</sup> time</b>								
1D06H-1D0DH	7430-7437						2-4	8



## Meter Clearance Event

Table 5-27 Meter Clearance Address

Modbus Address		Parameter Description	Data Type	R/W	Range	Default	Model	Register Number
Hex	Decimal							
1E00H-1E01H	7680-7681	Total meter clearance time	Word	R	0-999999		2-4	2
Last time meter cleared record								
1E02H-1E04H	7682-7684	Occur time	Word	R	YYMMDDhhmmss		2-4	3
Last 2 <sup>nd</sup> – 3 <sup>rd</sup> time								
1E05H-1E0AH	7685-7690						2-4	6

## RO Control Function (01H read, 05H write)

RO state read (01H)

Table 5-28 RO Control Function-01H Read

Modbus Address (HEX)	Parameter Description	Data Type	R/W	Data Range	Default	Model	Register Number
0000H	RO state	Word	R	1: ON 0: OFF			1

RO control (05H)

Table 5-29 RO Control function-05H Write

Modbus Address (HEX)	Parameter Description	Data Type	R/W	Data Range	Default	Model	Register Number
0000H	RO control	Word	W	FF00: ON 0000: OFF			1

## 5.4 BACnet Protocol Information

### 5.4.1. BACnet Overview and Introduction

Developed for Building Automation and Control Networks, BACnet is a standard communication protocol (ANSI/ASHRAE Standard 135-1995). The BACnet protocol can be found throughout commercial and industrial buildings because it supports communication and control of systems within a facility such as HVAC, lighting, and fire detection. The protocol was developed as a way to allow devices from a range of manufacturers to interoperate.

The BACnet protocol consists of Objects that contain different kinds of information and defines five groups (or classes) of 35 message types. Each Object has properties that contain data related to it. For example, one class contains messages for retrieving and manipulating object properties such as the common service request "ReadProperty." When the server machine receives this message from a client machine, it locates the requested property of the requested object and sends the value to the client.

Below is the example from the AXM-BMS (BACnet MS/TP protocol) of an Object for Total Watts:

**Object\_Name, P\_rms**

**Object\_Type, AnalogValue**

**Object\_Instance, 17**

**Present\_Value, watt, tot (value in watts)**

For additional information on the BACnet protocol, visit [www.bacnet.org](http://www.bacnet.org).

### 5.4.2. BACnet Protocol on the AcuRev 1310 Power Meter Series

The AcuRev 1310 Series Power Meter supports the BACnet communication protocol using BACnet MS/TP which allows it to communicate with most building automation/control systems.

BACnet MS/TP communication is supported via RS485. The AcuRev 1310 meter's BACnet MS/TP protocol supports 90 predefined BACnet objects that allow tracking of up to 90 measurements.

The AcuRev 1310 Series Power Meters only support BACnet MS/TP. BACnet IP (Ethernet) is not supported.

Table 5-30 BACnet MS/TP Characteristics

Data	Up to 480 bytes per telegram frame.
Installation	Any cable with at least 3 conductors can be used. Distance between nodes depends on baud rate.
Max Station	127 MS/TP masters.
Network Type	Serial RS485 with a Master/Slave Token Passing protocol.
Speed (Baud)	9600 kbit/s, 19200 kbit/s, 38400 kbit/s, 76800 kbit/s.
Topology	Serial RS485 with Master/Slave Token Passing protocol.

## RS485 Connection on the AcuRev 1310 Meter

The BACnet MS/TP module uses a standard RS485 connector to access the network.

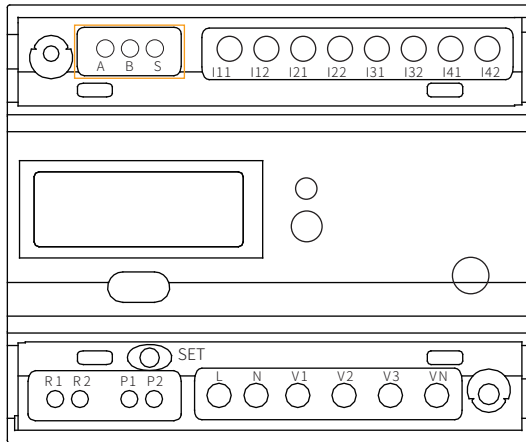

Figure 5-1: RS485 connection on meter

Table 5-31 Communications Terminal: A, B, S

Terminal Name	Name	Description
A	Data+	Positive RS485 RxD/TxD
B	Data-	Negative RS485 RxD/TxD
S	Shield	Cable Shield

### 5.4.3. Initializing BACnet Protocol on the AcuRev 1310 Meter

The AcuRev 1310 supports two protocols: BACnet MS/TP and Modbus RTU. All AcuRev 1310 series meters with firmware v2.16 or higher have the option of switching between communication protocols. By default, the meter is configured for Modbus RTU communication. Following are the steps required to change the meter’s protocol setting to BACnet MS/TP.

**DANGER**



During normal meter operation, caution should be used when handling the following as high voltage may be present:

- Terminal Blocks
- Current/Potential Transformer leads and the related circuits
- All primary and secondary circuits may contain lethal current and voltage.
- Contact with current channels must be avoided.

**STEP 1:** Remove the terminal covers to access the “SET” button. The “SET” button allows users to access the meter’s settings and make setup changes.

**1.** To open the terminal cover, remove the seal (if applicable) and then unscrew the sealing screws and lift the cover upwards.

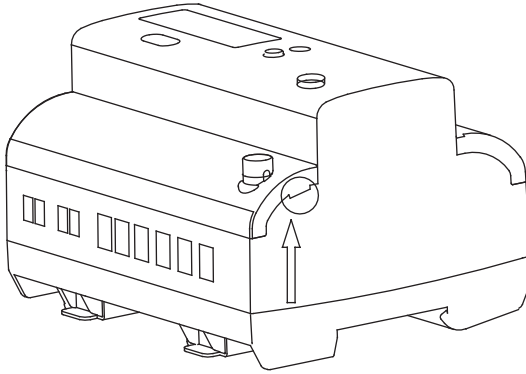

Figure 5-2: Removing terminal cover

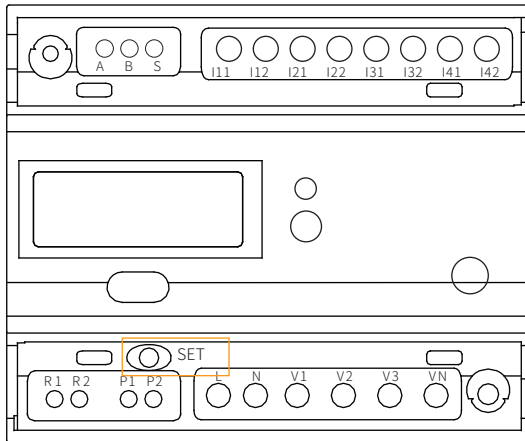

Figure 5-3: Accessing the “SET” button

**STEP 2:** Access the Settings menu to view the current protocol setting. Once the terminal cover is removed, the Settings menu can be accessed.

1. Press the “**SET**” button. You will be prompted by a password screen. This can be left as the *default (0000)*.
2. Press the “**SET**” button until you reach the **Communication Protocol** screen. By default, this is configured as “**0**” for Modbus RTU communication.
3. Press the “**SET**” button to enter edit mode (the setting will be flashing).
4. Press the “**SCROLL**” button to change the setting to “**1**” for **BACnet MS/TP** communication.
5. Press “**SET**” to confirm the setting.

Once the protocol is changed, other *BACnet settings* can be configured by pressing the “**SCROLL**” button to navigate through a series of screens.

1. **MAC Address Setting:** The default address is “**0**” and the range for MAC addresses is **0-127**. To configure the MAC address, press “**SET**” to enter edit mode and press “**SCROLL**” to change the value of the digit. Press “**SET**” again to confirm the digit and move to the next digit. Once the MAC address is configured, press “**SCROLL**” to navigate to the next configuration screen.
2. **Baud Rate:** By default, the baud rate is set for **38400**. The meter supports the following baud rates: *9600, 19200, 38400, and 76800*. To change the baud rate, press the “**SET**” button to enter edit mode and press “**SCROLL**” to select the desired baud rate. Press “**SET**” to confirm the setting and press “**SCROLL**” to navigate to the next configuration screen.
3. **Maximum Information Frame:** By default, this is set to 10. This value may be set from **1-250**. To configure the Maximum Information Frame, press “**SET**” to enter edit mode and press “**SCROLL**” to change the value of the digit. Press “**SET**” again to confirm the digit and move to the next digit. Once the Maximum Information Frame is configured, press “**SCROLL**” to navigate to the next configuration screen.
4. **Device Instance Number:** The default setting is “**1**,” but this number can be configured from *1-4194302*. To change the instance number, press the “**SET**” button to enter edit mode and press “**SCROLL**” to change the value of the digit. Press “**SET**” to confirm and move to the next digit. Once the instance number is configured, press “**SCROLL**” to navigate to the next configuration screen.
5. **Reset the Meter:** The final configuration screen will reset the meter. This is a necessary step in order to save configuration settings to the meter. To perform a reset, press the “**SET**” button to enter edit mode and press “**SCROLL**” to change the setting to “**1**.” Press “**SET**” to confirm the reset. This setting will change back to “**0**” signifying the reset was performed.

### 5.4.4. BACnet Objects

The AcuRev 1310 series meter supports 90 pre-defined BACnet objects based on the meter's real-time measurement parameters. There is no programming or mapping necessary to use this list of BACnet objects. The object's name easily identifies the type of measurement.

The following objects have the object type as Analog Inputs. The table below lists each of the objects with the instance number and the unit of measurement.

Table 5-32 BACnet Objects

Instance	Object Type	Name	Units
1	Object Analog Input	Frequency	Hertz
2	Object Analog Input	Phase A Voltage	Volts
3	Object Analog Input	Phase B Voltage	Volts
4	Object Analog Input	Phase C Voltage	Volts
5	Object Analog Input	Average Phase Voltage	Volts
6	Object Analog Input	Line Voltage AB	Volts
7	Object Analog Input	Line Voltage BC	Volts
8	Object Analog Input	Line Voltage CA	Volts
9	Object Analog Input	Average Line Voltage	Volts
10	Object Analog Input	Phase A Current	Amperes
11	Object Analog Input	Phase B Current	Amperes
12	Object Analog Input	Phase C Current	Amperes
13	Object Analog Input	Total Current	Amperes
14	Object Analog Input	Neutral Current	Amperes
15	Object Analog Input	Phase A Active Power	kW
16	Object Analog Input	Phase B Active Power	kW
17	Object Analog Input	Phase C Active Power	kW
18	Object Analog Input	Total Active Power	kW
19	Object Analog Input	Phase A Reactive Power	kVAR
20	Object Analog Input	Phase B Reactive Power	kVAR
21	Object Analog Input	Phase C Reactive Power	kVAR
22	Object Analog Input	Total Reactive Power	kVAR
23	Object Analog Input	Phase A Apparent Power	kVAR
24	Object Analog Input	Phase B Apparent Power	kVA
25	Object Analog Input	Phase C Apparent Power	kVA
26	Object Analog Input	Total Apparent Power	kVA
27	Object Analog Input	Phase A Power Factor	kVA
28	Object Analog Input	Phase B Power Factor	-
29	Object Analog Input	Phase C Power Factor	-
30	Object Analog Input	Total Power Factor	-

Instance	Object Type	Name	Units
31	Object Analog Input	Load Type	-
32	Object Analog Input	Active Power Demand	kW
33	Object Analog Input	Reactive Power Demand	kVAR
34	Object Analog Input	Apparent Power Demand	kVA
35	Object Analog Input	Phase A Current Demand	Amperes
36	Object Analog Input	Phase B Current Demand	Amperes
37	Object Analog Input	Phase C Current Demand	Amperes
38	Object Analog Input	System Active Power Demand Prediction	kW
39	Object Analog Input	System Reactive Power Demand Prediction	kVAR
40	Object Analog Input	System Apparent Power Demand Prediction	kVA
41	Object Analog Input	Phase A Current Demand Prediction	Amperes
42	Object Analog Input	Phase B Current Demand Prediction	Amperes
43	Object Analog Input	Phase C Current Demand Prediction	Amperes
44	Object Analog Input	Temperature of chips	Degrees Celsius
45	Object Analog Input	Import Active Energy	kWh
46	Object Analog Input	Export Active Energy	kWh
47	Object Analog Input	Import Reactive Energy	kVARh
48	Object Analog Input	Export Reactive Energy	kVARh
49	Object Analog Input	Import Apparent Power	kVAh
50	Object Analog Input	Export Apparent Power	kVAh
51	Object Analog Input	Active Energy Total	kWh
52	Object Analog Input	Active Energy Net	kWh
53	Object Analog Input	Reactive Energy Total	kVARh
54	Object Analog Input	Phase B Import Active Energy	kWh
55	Object Analog Input	Phase A Import Active Energy	kWh
56	Object Analog Input	Phase A Export Active Energy	kWh
57	Object Analog Input	Phase B Export Active Energy	kVA
58	Object Analog Input	Phase B Export Active Energy	kWh
59	Object Analog Input	Phase C Import Active Energy	kWh
60	Object Analog Input	Phase C Export Active Energy	kWh
61	Object Analog Input	Reactive Imported Q1	kVARh
62	Object Analog Input	Reactive Imported Q2	kVARh
63	Object Analog Input	Reactive Imported Q3	kVARh
64	Object Analog Input	Reactive Imported Q4	kVARh
65	Object Analog Input	Phase A Reactive Imported Q1	kVARh



Instance	Object Type	Name	Units
66	Object Analog Input	Phase A Reactive Imported Q2	kVARh
67	Object Analog Input	Phase A Reactive Imported Q3	kVARh
68	Object Analog Input	Phase A Reactive Imported Q4	kVARh
69	Object Analog Input	Phase B Reactive Imported Q1	kVARh
70	Object Analog Input	Phase B Reactive Imported Q2	kVARh
71	Object Analog Input	Phase B Reactive Imported Q3	kVARh
72	Object Analog Input	Phase B Reactive Imported Q4	kVARh
73	Object Analog Input	Phase C Reactive Imported Q1	kVARh
74	Object Analog Input	Phase C Reactive Imported Q2	kVARh
75	Object Analog Input	Phase C Reactive Imported Q3	kVARh
76	Object Analog Input	Phase C Reactive Imported Q4	kVARh
77	Object Analog Input	Phase A Import Apparent Energy	kVAh
78	Object Analog Input	Phase A Import Apparent Energy	kVAh
79	Object Analog Input	Phase B Import Apparent Energy	kVAh
80	Object Analog Input	Phase B Import Apparent Energy	kVAh
81	Object Analog Input	Phase C Import Apparent Energy	kVAh
82	Object Analog Input	Phase C Import Apparent Energy	kVAh
83	Object Analog Input	Current Imported Active Power Demand Peak and Happening Time	kW
84	Object Analog Input	Current Exported Active Power Demand Peak and Happening Time	kW
85	Object Analog Input	Last Month Imported Active Power Demand Peak and Happening Time	kW
86	Object Analog Input	Last Month Exported Active Power Demand Peak and Happening Time	kW
87	Object Analog Input	Total Times of Demand Reset	-
88	Object Analog Input	Last Demand Reset Happening Time	-
89	Object Analog Input	2nd Last Demand Reset Happening Time	-
90	Object Analog Input	3rd Last Demand Reset Happening Time	-

# *AcuRev 1310* DIN-Rail Power Meter

## Appendix

---

Appendix A - Functions List

Appendix B - Technical Data and Specification

Appendix C - Revision History

Appendix D - Alarm Parameters Comparison Table

Appendix E - Meter Event Flags: 32 bit

## Appendix A – Functions List

Function	AcuRev 1311	AcuRev 1312	AcuRev 1313	AcuRev1314
Bi-directional Energy Measurements			■	■
Active Energy	■	■	■	■
Reactive Energy		■	■	■
Apparent Energy		■	■	■
TOU		■	■	■
Power Demand		■	■	■
Peak Power Demand		■	■	■
Predictive Demand		■	■	■
Current Demand		■	■	■
Peak Current Demand		■	■	■
Voltage	■	■	■	■
Current	■	■	■	■
Neutral Current	Calculated	Calculated	Calculated	■
Residual Current				Calculated
Active Power	■	■	■	■
Reactive Power		■	■	■
Apparent Power		■	■	■
Apparent Power		■	■	■
Power Factor		■	■	■
Frequency		■	■	■
Clock		■	■	■
Running Time	■	■	■	■
Energy Pulse Output	■	■	■	■
Alarm Output		■	■	■
Alarm Event		■	■	■
Relay Output		⊖	⊖	⊖
RS-485 Modbus-RTU		■	■	■
Wiring Check	■	■	■	■
Temperature	■	■	■	■

■ : Fixed function

⊖ : Optional function

Blank: Function Not Supported

## Appendix B Technical Specifications and Parameters

The Transformer Connected to the Measurement			
Parameter	Accuracy	Resolution	Range
Active Energy	0.5%	0.1kWh	0-999999.9
Reactive Energy	0.5%	0.1kvar	0-999999.9
Apparent Energy	0.5%	0.1kVAh	0-999999.9
Voltage	0.5%	0.1V	175.0V-265.0V
Current	0.5%	0.001A	100mA-80A
Active Power	0.5%	0.1W	-80-80kW
Reactive Power	0.5%	0.1var	-80-80kvar
Apparent Power	0.5%	0.1VA	-80-80kVA
Power Factor	0.5%	0.001	-1.000-1.000
Frequency	0.2%	0.01Hz	45-65Hz
Power Demand	0.5%	0.1W/var/VA	80kW/kvar/kVA
Current Demand	0.5%	0.001A	80A

Power Supply	
Working Power Supply	100-415Vac, 50/60Hz; 100-300Vdc
Power Consumption	<2W or <10VA

Pulse Output	
Isolation Voltage	2500Vac
Load Voltage	0-25Vac
Load Current	10mA(max)

Relay Output	
Load Voltage	250Vac 30Vdc
Max Load Current	5A (Resistive Load)
Isolation Voltage	2000Vac(1min)
Action Time	10ms
Mechanical Life	20 million times
Electrical Life	Above 50,000 times (5A, 250Vac, Resistive Load)

Communication	
RS485 Baud Rate	1200-38400
Communication Protocol	Modbus-RTU
Infrared Communication	Non-contact infrared
Infrared Baud Rate	1200

Environment	
Working Temperature	-25-70° C
Storage Temperature	-40-85° C

## Appendix C Revision History

Version	Date	Description
V2.01	20141021	First Version
V2.02	20150923	Second Version
V2.03	20170910	Third Version

## Appendix D Alarm Parameters Comparison Table

Set Value	Corresponding Parameter	Set Value	Corresponding Parameter	Set Value	Corresponding Parameter
0	Total Current	1	Phase current A	2	Phase Current B
3	Phase Current C	4	Phase Average Voltage	5	Phase Voltage A
6	Phase Voltage B	7	Phase Voltage C	8	Line Average Voltage
9	Line AB Voltage	10	Line BC Voltage	11	Line CA Voltage
12	Frequency	13	Total Active Power	14	Phase A Active Power
15	Phase B Active Power	16	Phase C Active Power	17	Total Apparent Power
18	Phase A Apparent Power	19	Phase B Apparent Power	20	Phase C Apparent Power
21	Total Reactive Power	22	Phase A Reactive Power	23	Phase B Reactive Power
24	Phase C Reactive Power	25	Total Power Factor	26	Phase A Power Factor
27	Phase B Power Factor	28	Phase C Power Factor		

## Appendix E Meter Event Flags: bit32

Bit31	Bit30	Bit29	Bit28	Bit27	Bit26	Bit25	Bit24
Reserved	Reserved	Reserved	Reserved	Reserved	Reserved	Reserved	Reserved
Bit23	Bit22	Bit21	Bit20	Bit19	Bit18	Bit17	Bit16
Reserved	Reserved	Reserved	Reserved	Reserved	Reserved	Reserved	Reserved
Bit15	Bit14	Bit13	Bit12	Bit11	Bit10	Bit9	Bit8
Reserved	Reserved	Reserved	Reserved	Reserved	Reserved	Reserved	Reserved
Bit7	Bit6	Bit5	Bit4	Bit3	Bit2	Bit1	Bit0
M_EVENT_Missing_Sensor	M_EVENT_Over_Voltage	M_EVENT_Over_Current	M_EVENT_Low_PF	M_EVENT_Under_Voltage	M_EVENT_Power_Failure	Reserved	Reserved



MAKE ENERGY USAGE SMARTER

**ACCUEENERGY (CANADA) INC.**

22 Howden Road  
Toronto, ON M1R 3E4, Canada

TF: 1-877-721-8908  
INT: +1-416-497-4100  
FAX: +1-416-497-4130  
E: [marketing@accuenergy.com](mailto:marketing@accuenergy.com)

**ACCUEENERGY SOUTH AFRICA (PTY) LTD**

Castle Walk Corporate Park,  
Block B, Cnr. Nossob & Swakop Street  
Erasmuskloof, Pretoria, 0181  
South Africa

TF: +27 (0) 87 802 6136

