

AcuCT mV Series

333mV Split-Core Current
Transformer Installation Guide



Copyright © 2026 v1.0.0

All Accuenergy brands and trademarks in this document are the property of Accuenergy Inc. All other brands and trademarks may be the property of the respective owners of these rights.

This instruction may not be altered, copied or reproduced in whole or in part by any means without the expressed written consent of Accuenergy.

Please read this installation guide carefully before installation, operation, and maintenance of the AcuCT mV Series current transformers.

The information contained in this document is believed to be accurate at the time of publication, however, Accuenergy assumes no responsibility for any errors which may appear here and reserves the right to make changes without prior notice as part of continuing improvements. Please ask the local representative for the latest product specifications before ordering.

The following symbols appear throughout this documentation and on the AcuCT mV Series, in addition to the electrical warning of danger or safety risk during the installation and operation of the current transformers.



Electrical Shock Hazard: Contains information about procedures which must be followed to prevent the risk of electric shock and danger that can result in personal injury or death.



Safety Warning: Contains information about circumstances which if not considered may result in personal injury or death.



Info: An advance notice to provide additional information before an action is taken by the user.

Installation and maintenance of the AcuCT mV Series shall only be performed by qualified, competent professionals who have received training and have experience with high voltage and current devices.

Accuenergy shall not be responsible or liable for any damage caused by improper installation and/or operation.

Table of Contents

Safety and Critical Handling Requirements	5
Current Transformer Installation Safety.....	5
Installation Requirements and Operating Limits.....	6
Introduction.....	7
Overview	7
CT Orientation, Polarity, and Wiring Identification	8
Standard Split-Core Installation Procedure.....	9
Split-Core CT Installation.....	9
Warnings and Installation Considerations	12
Incorrect Installation Risk	12
Common Installation Errors	12
Best Practices	13
Accuracy Optimization	13
Wiring Practices.....	13
Installation Consistency	13
Commissioning Checklist.....	14

Safety and Critical Handling Requirements

**Info****Verify 333 mV Current Transformer Output Connection Before Energizing.**

Current transformers with a 333 mV output are designed with an internal burden resistor and are generally safe if the secondary circuit is open. However, disconnected or open output leads will prevent accurate current measurement and may cause incorrect meter readings, missed alarms, or improper system monitoring.

Current Transformer Installation Safety

- De-energize the primary conductor whenever possible before installing, removing, or repositioning the CT.
- Use lockout / tagout, arc-flash PPE, and site-approved live-work procedures where applicable.
- Confirm that the CT rated voltage, current ratio, output type, burden, and environmental ratings are suitable for the installation.
- Inspect the CT before installation. Do not use a CT with cracked housing, damaged hinge/latch, missing thumb screw, contaminated core faces, damaged secondary leads, or signs of overheating.
- Ensure the maximum current of the conductor does not exceed the rated current of the CT.
- Install indoors only unless the datasheet for the exact model and configuration states otherwise.
- Do not modify the CT housing, core mating surfaces, lead wires, mounting hardware, or insulation system.
- Ensure CTs installed around conductors do not occupy more than 75% of the available wiring space cross-sectional area, in accordance with applicable electrical codes.

Installation Requirements and Operating Limits

Parameter	Specifications	Operating Limits
Rated Voltage	600VAC, CAT III	Do not use above the approved circuit voltage rating.
Frequency Range	50 / 60 Hz	Confirm the frequency of the monitored system is within range.
Operating Temperature	-20°C to 55°C (-4°F to 131°F)	Confirm ambient conditions inside the enclosure.
Humidity	0% to 95% RH, Non-Condensing	Prevent condensation and water ingress.
Current Range	5% to 120% of Rated Current	Select CT ratio that matches expected operating current.
Secondary Output	333 mV	Use only with compatible 333 mV CT inputs.

Introduction

Overview

The AcuCT mV Series is part of the split-core current transformer family intended for retrofit or new installations where the primary conductor can pass through the CT window without disconnecting the conductor. The AcuCT mV Series supports standard 333mV secondary output.

Model	Rated Primary Current Options	Rated Secondary Output Options	Window Size	Exterior Dimensions
AcuCT-075	50A, 100A, 150A, 200A	333mV	19.0mm x 19.0mm (0.75" x 0.75")	50.8mm x 53.3mm x 17.0mm (2.00" x 2.10" x 0.70")
AcuCT-125	100A, 150A, 200A, 250A, 300A, 400A, 500A, 600A	333mV	31.8mm x 31.8mm (1.25" x 1.25")	82.5mm x 85.1mm x 26.0mm (3.25" x 3.35" x 1.02")
AcuCT-200	200A, 250A, 300A, 400A, 500A, 600A, 800A, 1000A, 1200A, 1500A	333mV	50.1mm x 50.1mm (2.00" x 2.00")	121.0mm x 127.0mm x 30.0mm (4.76" x 5.00" x 1.18")
AcuCT-3050	400A, 600A, 800A, 1000A, 1500A, 2000A, 3000A, 4000A, 5000A	333mV	76.2mm x 127.0mm (3.00" x 5.00")	146.0mm x 190.5mm x 35.6mm (5.75" x 7.50" x 1.40")

CT Orientation, Polarity, and Wiring Identification

Proper orientation is required for accurate real power measurement, correct power factor sign, and correct phase relationship between current and voltage inputs.



Info

CT Polarity Should Not be Inferred.

If commissioning shows negative power, reversed power factor, or incorrect phase angle, verify CT orientation and voltage phase assignment. Swap the polarity or reverse the CT after confirming the wiring diagram and metering configuration.

CT Components	Installation Instruction
White Lead	Connect the white secondary lead to the positive or high current or voltage terminal of the meter.
Black Lead	Connect the black secondary lead to the negative or return input of the meter.
Core Mating Faces	Keep clean and fully closed. Any gap or contamination can cause ratio error and phase error.
Press-Open Latch	Press the two side buttons to release the split-core CT assembly. Close the CT until the latch clicks and the core faces are fully seated.

Standard Split-Core Installation Procedure

Split-Core CT Installation

Step 1: Pre-Installation Checks

Verify that the current transformer model, ratio, and output match the meter and application. Inspect for any physical damage and confirm that the cable or conductor size fits within current transformer window.

Step 2: Connect CT Secondary Leads

Connect the white positive leads and black negative leads to the CT terminals on the meter and check for correct polarity. It is recommended to terminate the current transformer leads before installing the CT onto live conductors.



Info

Check the meter wiring diagram as each meter termination may vary across different models and manufacturers.

Route the CT secondary leads away from sharp edges, moving parts, high-temperature surfaces, and high-noise conductors. Keep the secondary wiring as short as practically possible to reduce burden and noise interference.

Step 3: Open the Split-Core CT

1. Hold the bottom section and pull the split-core top section apart to open the CT as depicted in Figure 1.

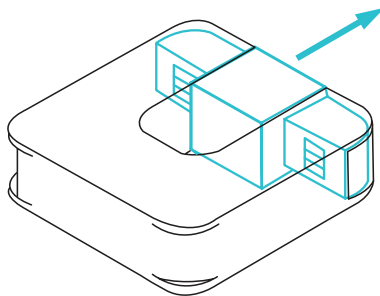

Figure 1 Opening the Split-Core Current Transformer

2. Separate the removable top section of the CT core to create an opening for the cable or conductor.

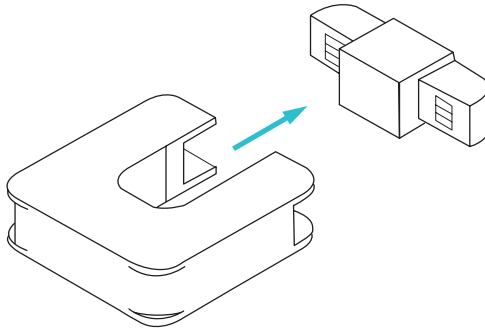

Figure 2 Fully Open Split-Core CT for Conductor Placement

Step 4: Install Around Conductor

1. Place the CT around the primary phase conductor or cable. As depicted in Figure 3, ensure correct orientation by pointing the arrow towards the load.

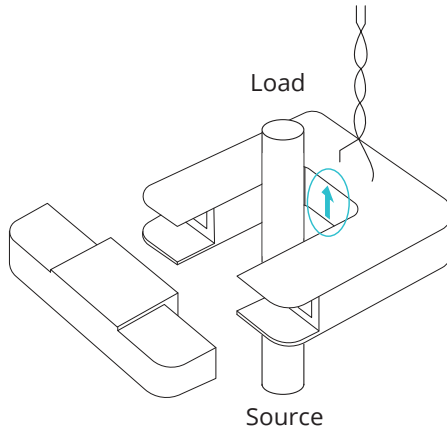

Figure 3 CT Orientation around Conductor

2. If required, secure the current transformer as depicted in Figure 4. The cable tie is intended only to prevent movement of the CT and must not be used to forcefully close the CT core. Ensure the core is fully seated and latched before energizing the circuit.

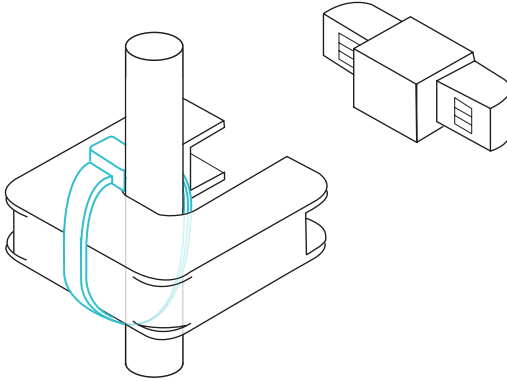

Figure 4 Cable Tie to Secure CT

Step 5: Close the CT

1. Confirm the secondary leads are connected to the meter current input.
2. Reattach the removable top section of the CT and ensure it is fully seated and latched until a click sound is heard.



Ensure CT is fully latched as even a small air gap can significantly reduce the measurement accuracy.

Step 6: Final Verification

1. After the installation steps 1 to 5 are complete, perform a final check and confirm correct phase association, proper polarity, and closure is secured.
2. If required, repeat steps 1-6 for the remaining phases.

Warnings and Installation Considerations

Incorrect Installation Risk

Improper installation may result in inaccurate measurements, negative or reverse readings, reducing system reliability.

Common Installation Errors

Frequent errors observed are installing the CT backwards with incorrect polarity or simultaneously clamping the CT around multiple different phase conductors or mixing current and voltage phases. If the latch is not properly closed, it leaves the CT partially open leading to incorrect readings.

Best Practices

Accuracy Optimization

To achieve optimal performance, keep the CT core clean and fully closed. The AcuCT mV Series meets accuracy specifications but place the conductor in center within the window to ensure maximum accuracy. Use cable ties to hold the CT in position and align the conductor. Maintain correct phase alignment with voltage inputs.

Wiring Practices

Route the CT secondary leads away from high-voltage conductors and avoid unnecessary lead extensions. To avoid noise interference, use twisted shielded wiring.

Installation Consistency

Maintain a consistent CT orientation across all measured phases and clearly label the CT, such as Phase A, B, C or R, Y, B. If possible, complete the wiring prior to CT installation.

CT Secondary Safety

Condition	333 mV Secondary
Open-Circuit Risk	Low
Shorting Required	No
Connect Leads Before Installation	Recommended

Commissioning Checklist

Check	Acceptance Criteria	Result
Mechanical Closure	<ul style="list-style-type: none"> • CT core fully closed • Latch clicked into place • No visible air gap 	Pass / Fail
Orientation	<ul style="list-style-type: none"> • Confirm the source side and arrow-to-load direction 	Pass / Fail
Secondary Polarity	<ul style="list-style-type: none"> • White to positive • Black to negative 	Pass / Fail
Ratio Setting	<ul style="list-style-type: none"> • Meter ratio matches CT order code and primary current rating 	Pass / Fail
Phase Mapping	<ul style="list-style-type: none"> • Current phase correctly corresponds to voltage phase 	Pass / Fail
Reading Magnitude	<ul style="list-style-type: none"> • Current reading matches expected load current within tolerance 	Pass / Fail
Power Sign	<ul style="list-style-type: none"> • kW and power factor signs are correct under normal load 	Pass / Fail
Lead Strain Relief	<ul style="list-style-type: none"> • Secondary leads secured and protected from sharp edges, moving parts, and high-noise conductors 	Pass / Fail
Abnormal Condition	<ul style="list-style-type: none"> • No abnormal heat, vibration, smell, noise, or visible damage 	Pass / Fail

ACCUEENERGY

MAKE ENERGY USAGE SMARTER

For additional help please reach out to:

Accuenergy Sales

Email: marketing@accuenergy.com

Tel: 416-497-4100 ext. 1

Accuenergy Technical Support

Email: support@accuenergy.com

Tel: 416-497-4100 ext. 3



ISO 9001, 14001
& 45001 Certified



ISO 27001 &
50001 Certified



Accuenergy Inc.

Los Angeles - Toronto - Pretoria

North America Toll Free: 1-877-721-8908

Web: www.accuenergy.com

Revision Date: June 2026 Version: 1.0.0
Specs Subject To Change Without Notice.

